

# Open 3K

## Smart videophone

### With built-in keypad



[www.avidsen.com](http://www.avidsen.com)

Guide d'installation et d'utilisation  
Installation and User Manual  
Installatie- en gebruikersgids  
Installations-und Bedienungsanleitung  
Guía de instalación y de uso  
Manual de instalação e utilização  
Manuale d'uso e installazione

Fig. 1

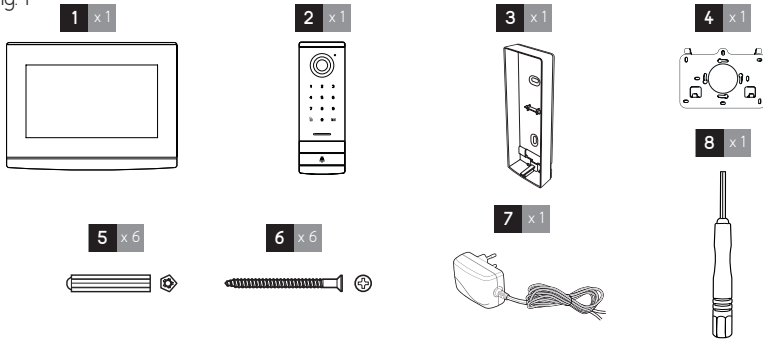

Fig. 2

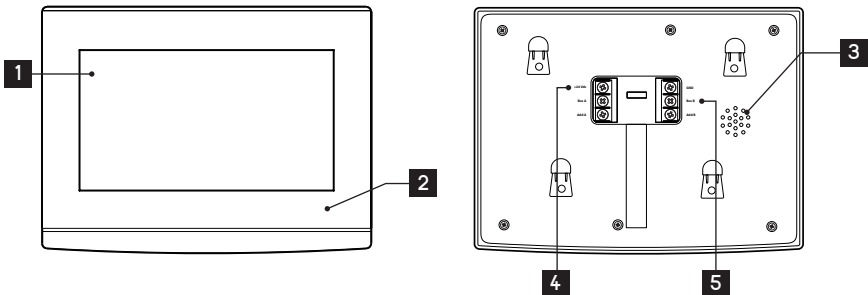
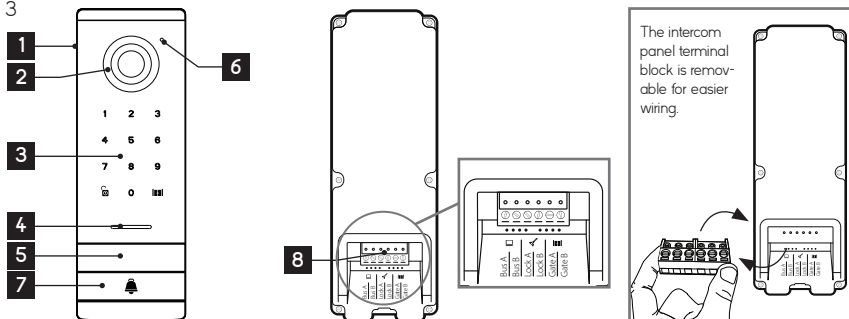

Fig. 3



To find out more, please check out our tutorials on our website: [www.avidsen.com/fr/assistance/tutoriel-sav](http://www.avidsen.com/fr/assistance/tutoriel-sav)

Fig. 4

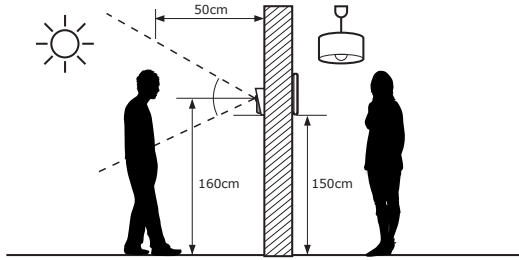

Fig. 5

intercom panel

monitor

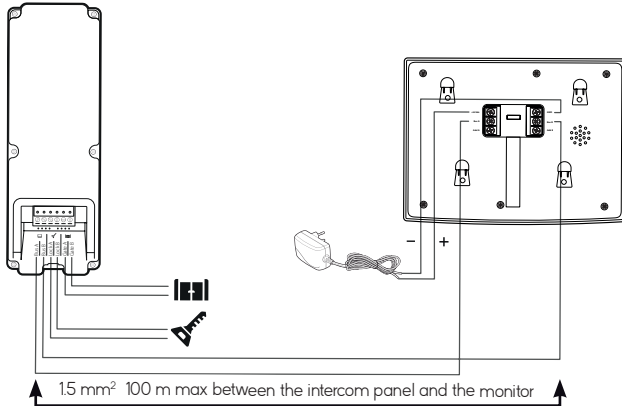
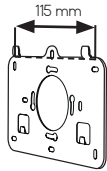

Fig. 6.1



$\phi 6$  mm

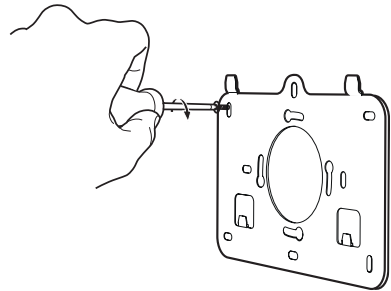
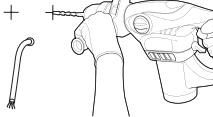

Fig. 6.2

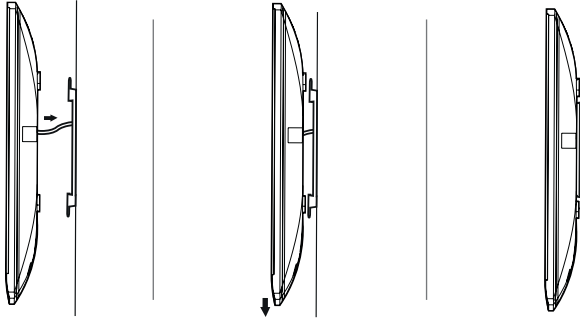

Fig. 7

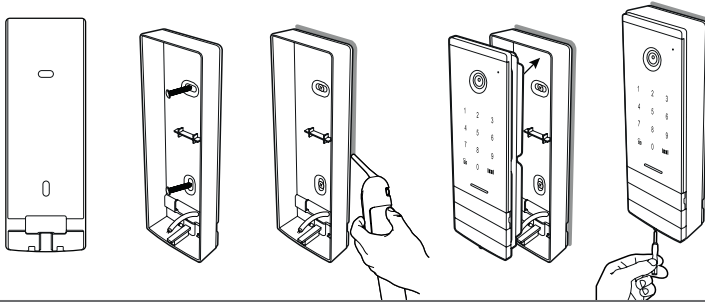

Fig. 8 intercom panel

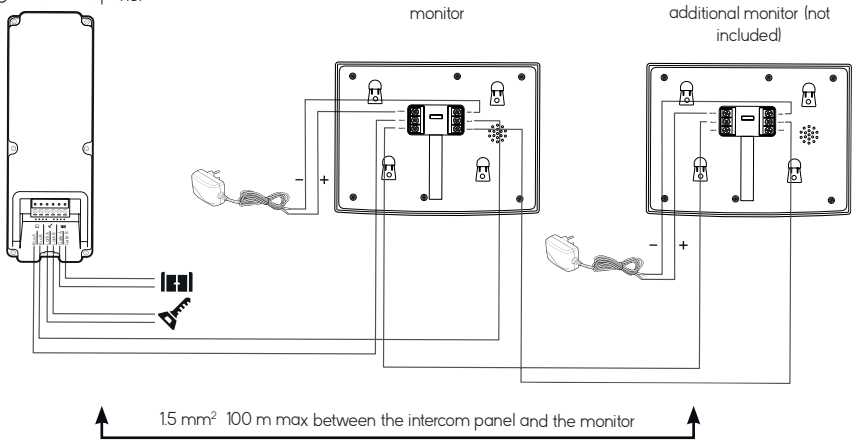

Fig. 9

	2 x Ø 0.75mm <sup>2</sup>	2 x Ø 1,5mm <sup>2</sup>
	5 → 50m	5 → 100m

## CONTENTS

---

A - KIT CONTENTS.....	02
B - DESCRIPTION OF MONITOR .....	02
C - DESCRIPTION OF THE INTERCOM PANEL.....	02
D - INSTALLATION.....	03
1 - Wiring	
2 - Installing the intercom panel	
3 - Connecting an electric strike plate	
4 - Connecting a motor drive	
E - MONITOR USER MANUAL.....	05
1 - Navigating the menus	
2 - General menu	
3 - Sound adjustment menu	
4 - intercom mode	
5 - WiFi menu	
6 - Photo/video menu	
7 - Advanced settings (other settings menu)	
F - CONNECTING YOUR EXTEL OPEN 3K VIDEOPHONE TO YOUR SMARTPHONE .....	11
1 - Preparing the videophone	
2 - Pairing your doorkeeper with a smartphone	
3 - Interface functions	
4 - Settings accessible in the application	
G - TECHNICAL SETTINGS .....	23
H - WARRANTY .....	24
I - SAFETY INSTRUCTIONS .....	25
J - DECLARATION OF CONFORMITY .....	26

## A - KIT CONTENTS

Fig. 1

1	Monitor
2	Intercom panel
3	Surface mounting bracket
4	Monitor fixing bracket
5	Plug

6	Fixing screws for monitor bracket and surface mounting bracket
7	Mains adapter
8	Hexagonal screwdriver 1.5 mm

## B - DESCRIPTION OF MONITOR

Fig. 2

1	7" colour touchscreen
2	Microphone
3	Loudspeaker

4	Power supply connectors
5	Intercom panel and/or secondary monitor communication connectors

## C - DESCRIPTION OF THE INTERCOM PANEL

Fig. 3

1	Protective mirrored façade
2	Camera and infrared LEDs
3	Touchscreen code pad
4	Loudspeaker
5	Name holder (the transparent plastic can be peeled back to write on the label)

6	Microphone
7	Call button
8	Monitor, electric strike plate and gate motor drive connectors (for details, see Fig. 7)

### 1 - WIRING

---

- The wiring diagrams for the various configurations can be found in:
  - **Fig5:** 1 family – 1 monitor
  - **Fig. 8:** 1 family – 2 monitors

 **Warning:** the second monitor is neither supplied nor available separately. Please get a second kit if you wish to use a second monitor.

- Do not increase the number of insulating screw joints or connectors on the connecting wire between the intercom panel and the monitor
- To prevent risks of interference and malfunction, do not pass the wire for your videophone through the same sheath as the electrical wires.
- Keep the connecting wire between the intercom panel and the monitor more than 50cm away from any electromagnetic interference (230V cable, WiFi equipment, microwave ovens, etc.).
- You can connect and use an electric emission strike plate (not included) with your intercom panel, with mechanical memory.
- To ensure good audio and video quality, it is advised to not use more than 100 m of cable between the intercom and the intercom panel. The cable size to be used is shown in **Fig9**.

 **Warning:** Do not under any circumstances double wires to increase the wire size.

- If a wire is incorrectly connected or disconnected after powering up, the entire system must be disconnected before any intervention. Your gate can be connected to the power supply again once the defective connection has been repaired.

**Note:** if you are testing the product prior to installing it, it is recommended that you place the unit on a flat surface.

### 2 - INSTALLING THE INTERCOM PANEL

---

**Note:** If you test your product before installing it, put the monitor on a flat surface and make sure not to test it with the intercom panel and the monitor in the same room. If you do so, the videophone will emit a piercing sound (feedback effect).

#### Installing the intercom panel (*fig. 4, 7 and 6*)

- Remove the screw under the intercom panel (1).
- Tilt the intercom panel forwards (2).
- The lens of the panel must be placed at a height of around 160 m (5).
- Firmly attach the mount with screws (2) and apply a silicon seal (3) between the mount and the wall to prevent water from running between the two. \*Do not use acetic acid-based silicone (vinegar odour).
- After wiring, fit the intercom panel onto its mount (4).
- Re-install the attachment screw (5).

**Important:** Do not have the camera directly exposed to the sun or facing a reflective surface.

At the same time, remember to properly insert the intercom panel lug in the hole on the weather-proof shield.

**Tip:** it is recommended that the wires be passed through a sheath to protect them from impacts and weather.

#### Installing the monitor (*fig. 6.1 and 6.2*)

- Attach the wall bracket so that the screen of the monitor will be around 160 m high.
- Connect the wires coming from the intercom panel.
- Insert the adapter wires in the back of the monitor (without plugging it into the wall socket).

 **Warning:** you must comply with the polarity (red and black terminals).

- Install the monitor (1) on the wall bracket.
- Plug the adapter into the 230 V wall socket-.

### 3 - CONNECTING AN ELECTRIC STRIKE PLATE

---

Connect the strike plate directly to Lock A and Lock B terminals on the back of the intercom panel (no need to observe polarity).

Note that this function is only valid if the screen is on. The unit may buzz at the time the command is given.

For wiring, refer to the reverse of the panel and the diagram in **Fig5**.

#### **Important:**

- The maximum distance between the intercom panel and the electric strike plate or electric lock is 50 m maximum. The wire size to be used is 0.75 mm<sup>2</sup>.
- The use of a 12 V/1.1 A max. strike plate with mechanical memory is recommended.

### 4 - CONNECTING A MOTOR DRIVE

---

Connect it directly to Gate A and Gate B terminals on the back of the intercom panel (no need to observe polarity).

Note that this function is only valid if the screen is on. The panel provides a 'dry' contact connection, without an electric current, to connect to the button for your automated gate. For wiring, refer to the reverse of the panel and the diagram in **Fig5**.

#### **Important:**

- This function is only valid if the screen is on.
- The maximum distance between the intercom panel and the gate motor drive is 50 m. The wire size to be used is 0.75 mm<sup>2</sup>.

## 1 - NAVIGATING THE MENUS

**Important:** when starting up your product for the first time, the monitor will first tell you where to find these instructions (QR code to be scanned), before asking you in which language and on which WiFi network to operate. Once you have completed (or postponed) these steps, the main screen display appears (current date and time).

The Extel Open 3K monitor screen is touch-sensitive. The settings menus can be accessed by clicking on the main screen:

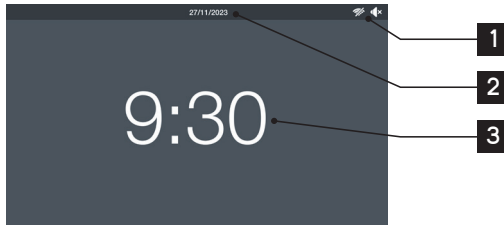

1	Notification zone (WiFi and Internet connection status, sound volume status, indicator of visits in your absence, etc.).
2	Current date: If the product is connected to the Internet and associated with the Extel Connect application, the time and date are automatically controlled by the network.
3	Current time

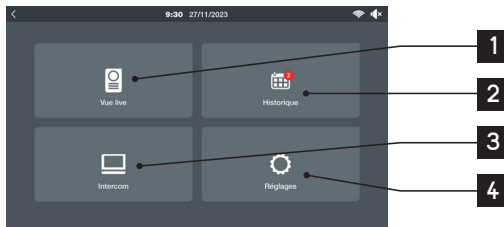

1	View the image in real time from the intercom panel
2	Access to photos and videos captured in your absence during visitor calls
3	Calling a secondary monitor Only useful if the system features a second monitor (not supplied)
4	Access to the device settings menus

## 2 - GENERAL MENU

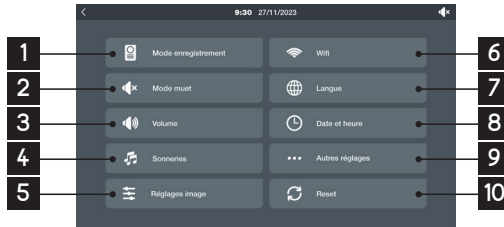

1	Selects the type of recording when the intercom panel call button is pressed: photo, video or disabled.
2	Mute function: allows you to mute incoming call chimes while maintaining the rest of the videophone's functions. A time slot can be programmed if required. Example: no chimes from 11pm to 6am.
3	Sets monitor volume: in chime mode, during a call, intercom panel volume control during a call. Activates/disables screen beeps when the touchscreen is pressed.
4	Selects the monitor chime for incoming calls and for intercom mode if the system features a second monitor. 6 chimes are available, plus 2 customised mp3 chimes that can be added via the mobile application.
5	Adjusts luminosity, contrast and colours of the intercom panel image.

6	Selects the delay between the monitor chime and the chime on the mobile application (to give occupants on site time to respond). Access to settings for connecting to the WiFi network and QRCode for associating the product with the mobile application.
7	Selects the monitor's display language.
8	Sets time and date. The settings are greyed out when the monitor is connected to the Internet: its time and date are automatically set by the network.
9	Electric strike plate control duration. Selects main monitor/secondary monitor if the system features an additional monitor.
10	Resets the photo/video memory or the entire device. Current firmware version

### 3 - SOUND ADJUSTMENT MENU

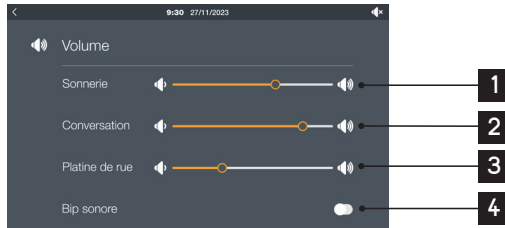

- |          |  |
|----------|--|
| <b>1</b> | Monitor chime volume. Click on  or  on the edges of the bar to adjust the volume.                            |
| <b>2</b> | Volume of the monitor loudspeaker during a call. Click on  or  on the edges of the bar to adjust the volume. |

- |          |   |
|----------|---|
| <b>3</b> | Volume of the intercom panel loudspeaker during a call. Click on  or  on the edges of the bar to adjust the volume. |
| <b>4</b> | Activates/disables beeps when you click on the screen.  |

### 4 - INTERCOM MODE

If a secondary monitor is connected, you can call up a monitor using the second monitor from this menu.

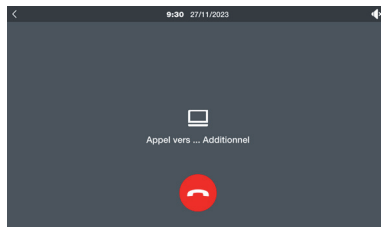

### 5 - WIFI MENU

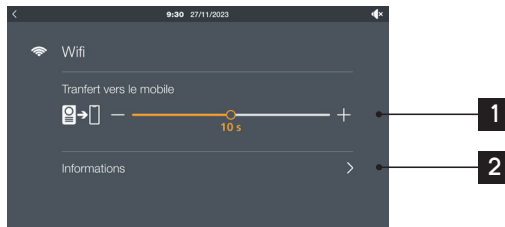

- |          |   |
|----------|---|
| <b>1</b> | Sets the delay between the monitor chime and the chime on the mobile application: the delay can be set from 0 to 20s to give occupants time to respond when a visitor is present. |
| <b>2</b> | WiFi network and Internet connection settings   |

A click at the bottom right corner of the screen brings up the WiFi and Internet settings:



- |          |  |
|----------|--|
| <b>1</b> | WiFi network in use: click on this area to display the surrounding networks menu and select one.   |
| <b>2</b> | Unique product identifier.   |
| <b>3</b> | <p>Unique product QR Code:<br/>this QR Code will be requested by the application during set-up using the Extel Connect application.</p> <p><b>Please note:</b> this QR Code will only appear if the monitor is connected to WiFi and the Internet. If the QR Code is missing from this page, check your network.</p> |

By clicking on the name of the network in use, or on the 'Ajouter réseau' ('Add network') button if you are not yet connected to any network, the monitor displays a list of surrounding networks.

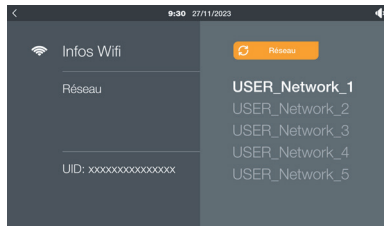

Click on the desired network and enter the key (password) for your network to connect your videophone.

## 6 - PHOTO/VIDEO MENU

In the event of missed calls, if you have activated photo-taking or video-recording in the monitor settings, the monitor will indicate the presence of unwatched recordings from the main page:

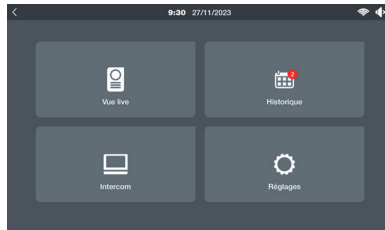

Click on the 'Historique' ('History') icon to access the photo and video recordings in the monitor's internal memory:



The nature of each recording (photo or video) is indicated by the icon. The time and date the photo was taken or the video was recorded are also shown. Click on one of the files to display or play it.

## 7 - ADVANCED SETTINGS (OTHER SETTINGS MENU)

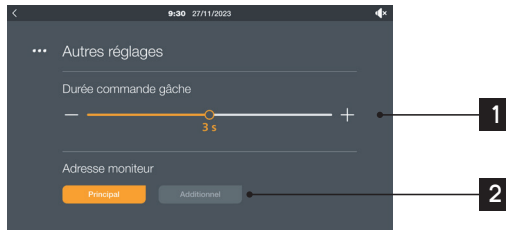

- |   |  |
|---|--|
| 1 | Electric strike output control time adjustable from 1 to 5s.<br>Note: the gate output control time is set to 1s.   |
| 2 | Monitor address: only useful if the system features two monitors. <ul style="list-style-type: none"> <li>• If your monitor is the one connected to the intercom panel and the second monitor, you must select 'Principal' ('Main')</li> <li>• If your monitor is the one that is only connected to the 'Principal' ('Main') monitor, you must select 'Additionnel' ('Additional')</li> </ul> |

**⚠ Warning:** if you change the 'Principal'/'Additionnel' ('Main'/'Additional') allocation, for the configuration to be applied, you need to disconnect both monitors from the system at the same time and then reconnect them.

**Note:** the intercom panel keypad cannot be configured from the monitor. It is configured in the application.

### 1. PREPARING THE VIDEOPHONE

---

When connecting for the first time, you need to pair your Extel Open 3K doorkeeper with your smartphone. When the monitor is switched on for the first time, you will be prompted to do this immediately after selecting the language. If you haven't already done so, connect your doorkeeper to your WiFi network by going to the WiFi sub-menu, then click on the bottom right corner:

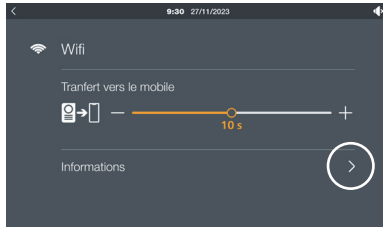

Next, click on the 'Ajouter réseau' ('Add network') button on the right to start detecting nearby WiFi networks:



After a few seconds, the surrounding networks are listed on screen. Click on the desired network, then enter its key (password) and confirm to connect your videophone to WiFi and the Internet.

### 2. PAIRING YOUR DOORKEEPER WITH A SMARTPHONE

---

Install the 'Extel Connect' application on your smartphone. The application is available free of charge on Google Play for your Android smartphone or on the app store for your iPhone.

Once your doorkeeper is connected to your WiFi network and to the Internet, launch the application on the smartphone, having connected the smartphone to the WiFi network the doorkeeper will use:

Please note: screenshots are from the Android version of the application. The iPhone procedure is identical. Download the Extel Connect application from Google Play or the App Store.





1. In the smartphone app, click on the '+' symbol.



2. Select 'Mon périphérique est déjà connecté à Internet' (My device is already connected to the Internet).



If your doorkeeper is already connected to your WiFi network, it will be automatically detected by the application after a few seconds. Click on it.

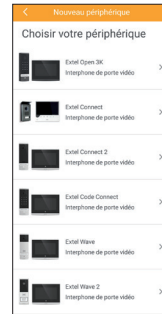

Otherwise select 'Extel Open 3K'



Select 'aucun mot de passe défini?' (no password set?) Scan the QR code in the product menu. Then select 'QR code Scan'.

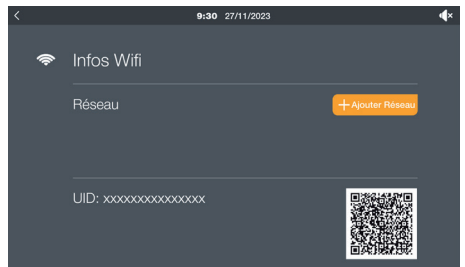

The QR Code to be scanned appears in your monitor's advanced settings

**Remember:** if no QR Code appears in this menu, your

## F - CONNECTING YOUR EXTEL OPEN 3K VIDEOPHONE TO YOUR SMARTPHONE

monitor is not connected to the Internet. Connect your monitor to the Internet before continuing.

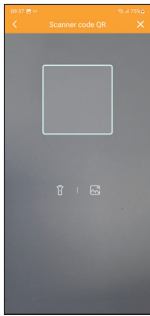

3. Then scan the QR Code on your doorkeeper's monitor screen.



4. If the QR code scan is correct, the application should find the Extel Open 3K monitor. Press 'Ajouter' ('Add').

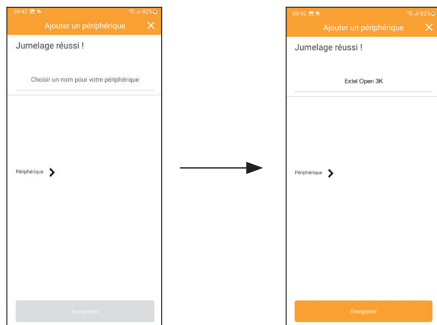

5. The message 'Jumelage réussi' [Pairing successful] should appear. Enter a name to identify your video doorkeeper and press 'Enregistrer' [Save].

If the video doorkeeper is connected to the application for the first time, the application immediately asks you to create a 6 to 16 digit code to secure the connection:

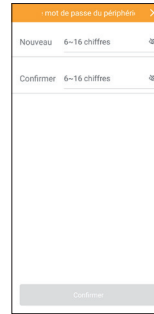



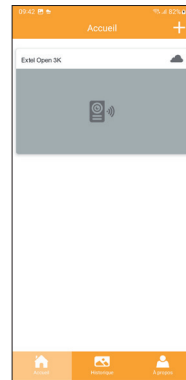

Create and copy the code of your choice, then confirm.









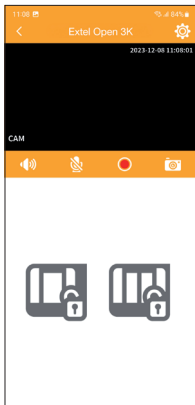

### 3. INTERFACE FUNCTIONS



-  Contains the different devices and enables switching to monitoring mode
  -  Retrieves intercom activity and calls made
  -  "A propos" (About) tells you the application's software version
  -  Enables you to add a device
-  Click on the image to enter monitoring mode

#### Monitoring mode



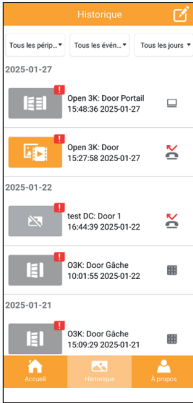

-  Enables you to manage the videophone settings: name, password, WiFi network.
-  Activate/deactivate the sound
-  Activate/deactivate the microphone
-  Take a video that can be viewed in the log
-  Take a photo that can be viewed in the log
-  Open the electric strike plate
-  Open the gate

### Log mode





 Allows you to edit photos/videos (delete and select all)

   Allows you to sort photos/videos.

   The icons on the right give you additional information: source (mobile application, intercom panel keypad, monitor) and nature (answered call, missed call)

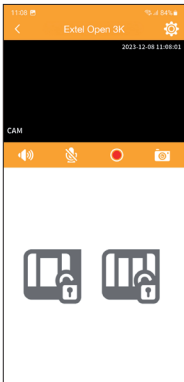
## 4. SETTINGS ACCESSIBLE IN THE APPLICATION



Many configuration options can be accessed by clicking on the icon  at the top right of the live image screen.

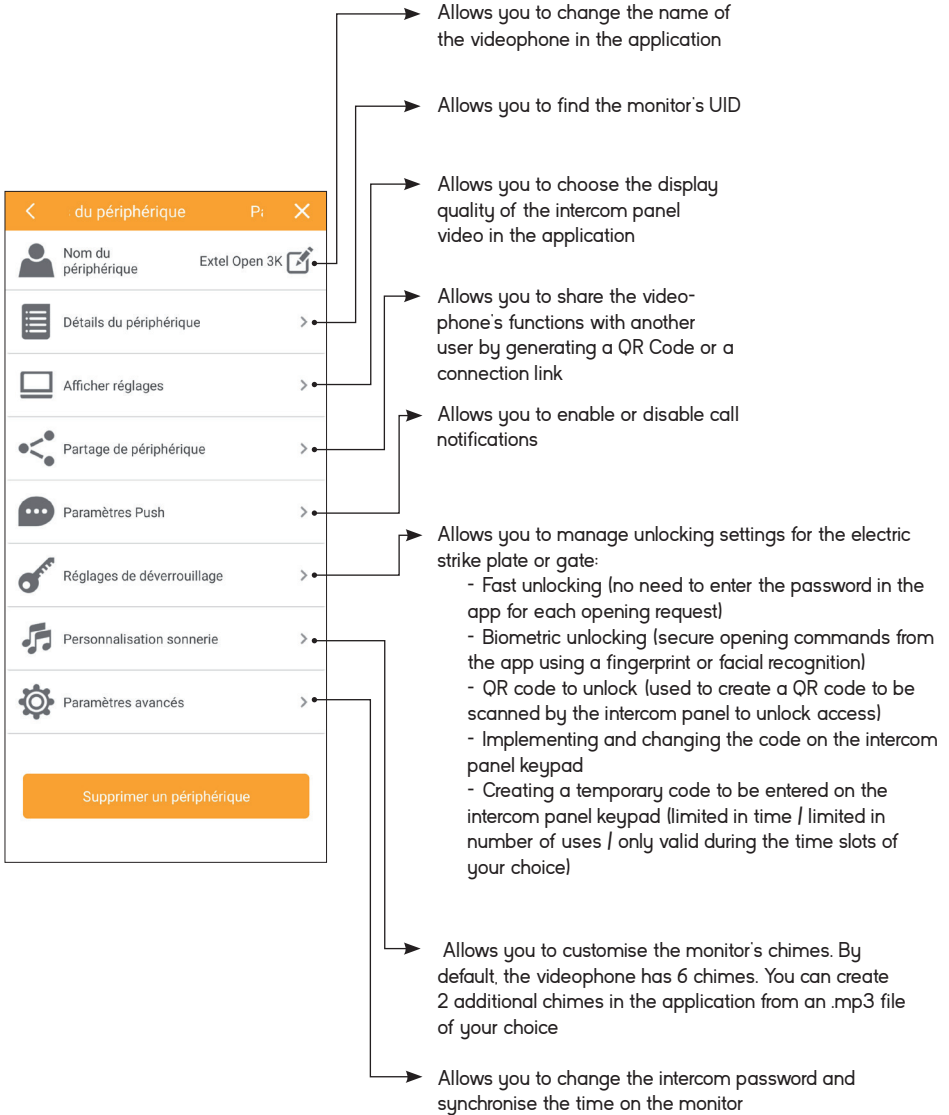

## F - CONNECTING YOUR EXTEL OPEN 3K VIDEOPHONE TO YOUR SMARTPHONE

### Customising monitor chimes

By default, your videophone has 6 chimes that you can choose from the Chimes menu. You can add 2 customised chimes from the Extel Connect application using the .mp3 file of your choice, then use them on your videophone monitor.

#### A. Android

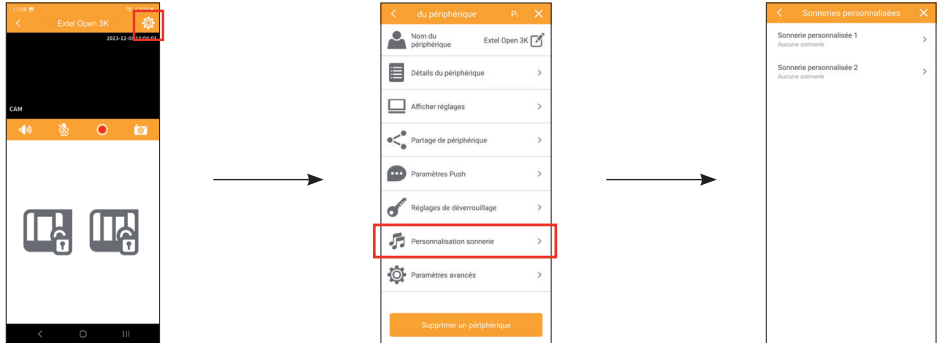

Select customised chime 1 or customised chime 2



Click on 'sonnerie uploadée' ('uploaded chime') to upload a chime or music file in .mp3 format from your phone's memory.

Once the chime has been sent to your monitor, it can be selected on the monitor from the Chimes menu. Customised chime no. 1 will be chime no. 7 on the monitor, customised chime no. 2 will be chime no. 8.

B. iOS

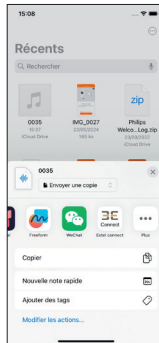

From your iPhone's file browser, share a chime or music in .mp3 format with the Extel Connect application. You can share up to 3 files with the application.



Once the chime or music has appeared in the Extel Connect application, choose the product to which the chime should be sent.

Once the chime has been sent to your monitor, it can be selected on the monitor from the Chimes menu. Customised chime no. 1 will be chime no. 7 on the monitor, customised chime no. 2 will be chime no. 8.

## F - CONNECTING YOUR EXTEL OPEN 3K VIDEOPHONE TO YOUR SMARTPHONE

### Creating QR codes to unlock access

The QR code creation feature allows you to generate a QR code that you can send to whomever needs to open the electric strike plate in your absence. To access this menu:

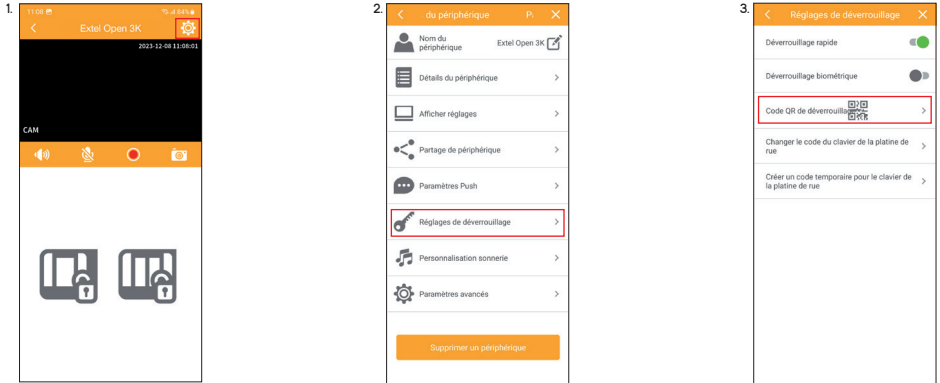

Start creating a new QR code and give it a name so that you can recognise it later (and delete it if necessary, for example). Next, choose whether the QR code will open the gate or the electric strike plate.

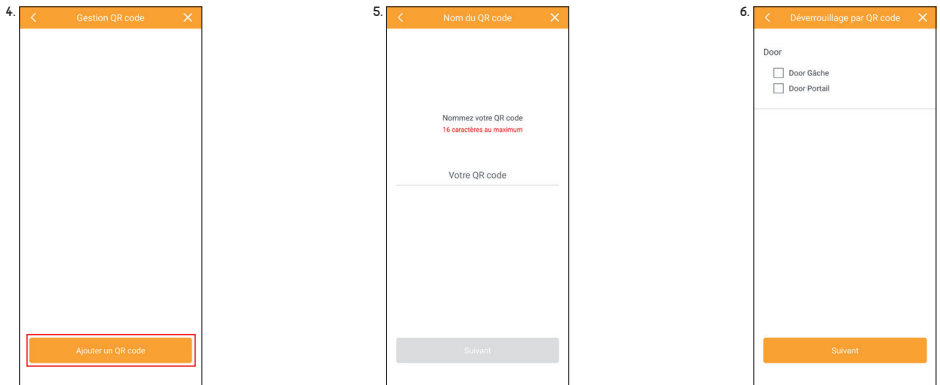

You must now choose whether the QR code to be created will be permanently valid (regardless of the time and date) or temporary (valid only for a given period and/or only on certain days, from a certain time to another, etc.)

Permanent: the QR code will be valid 7 days a week, 24 hours a day, until it is deleted from the app.

Temporaire: allows you to choose when the QR code will be authorised to open access.

Specify a start time and date here and an end time and date if you wish.

Customised time: by activating this option, you can define days and times of validity (e.g. for domestic staff, tradespeople, etc.).

Click on one of the days of the week if you want to define validity time slots for the selected day.

If you click on one of the days, you can then define up to 3 time slots for the validity of the QR code being created. Outside the specified times, the QR code will be read by the intercom panel but will not open access.

Set up to 3 QR code validity time slots here

Select the day or days for which the set time slots are to be applied

Click on Enregistrer (Save) to return to the previous screen

## F - CONNECTING YOUR EXTEL OPEN 3K VIDEOPHONE TO YOUR SMARTPHONE

After clicking on Suivant (Next), the QR code is created and its summary is displayed:



The screenshot shows a mobile application interface titled "Informations QR code". It contains the following elements:

- Nom**: Localitaire (Name, action and type of QR code created)
- Door**: Door Portail (Location)
- Validité**: Permanent (Validity)
- A large QR code.
- Three orange buttons at the bottom: **Télécharger** (Click here to download a copy of the QR code to your smartphone as an image file), **Partager** (Click here to share the QR code with its user, by email / MMS / instant messaging, etc.), and **Supprimer** (Click here to delete the QR code. In this case, its presentation will have no effect on the intercom panel).

**Using the QR Code:** once the user to whom you have sent the code has received it, they can simply scan the QR Code image on the camera to unlock access.

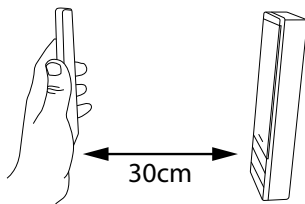

### Configuring and using the intercom panel keypad:

The code of the keypad on the front of the intercom panel is configured from the settings menu. You can create two codes: the permanent code, which is valid regardless of the time or date, and the temporary code, for which you can specify a number of uses, a start date, an end date and/or the time slots on weekdays or weekends when the code can be used.

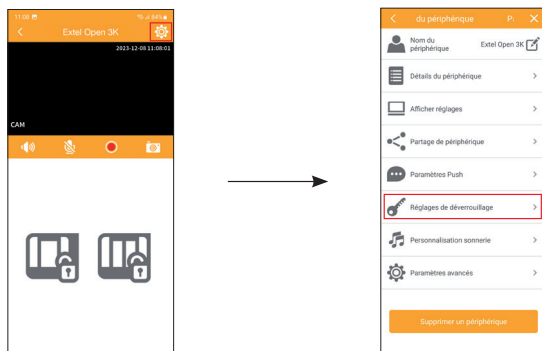

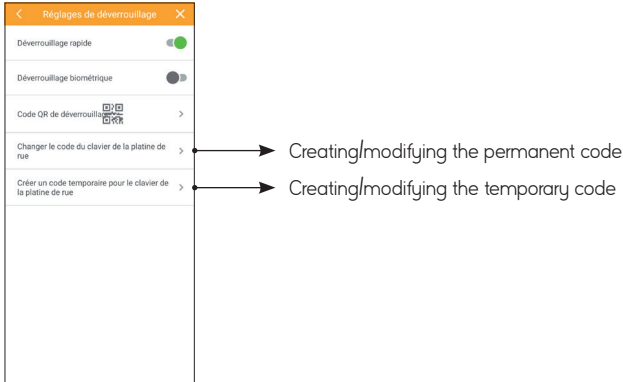

Programming the temporary code is similar to programming a temporary QR code:

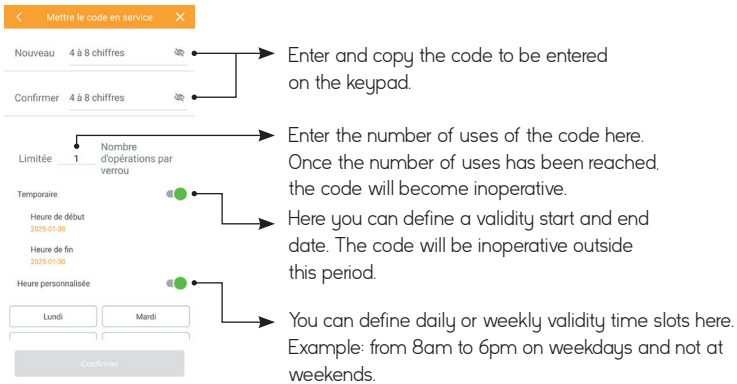

**Using the intercom panel keypad:**

You can enter the permanent or temporary code on the intercom panel keypad at any time.

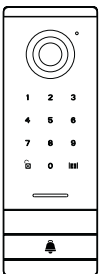

Next, click on the icon to open the strike plate or to open the gate:

- If you hear 1 beep in response: the electric strike plate has been unlocked.
- If you hear 2 beeps in response: the gate control has been activated.
- If you hear 3 beeps in response: the code entered is wrong or, in the event of a temporary code, outside the programmed validity range.

## G - TECHNICAL SETTINGS

Wiring	2-wire
Max. distance	Intercom panel/camera - screen: 100 m
Control	Lock and gate
Doorbell melody	6 Chimes + 2 customisable chimes via mp3 Sound level: 85 dB
Screen features	Diagonal: 7" (18 cm) Resolution: 1024 x 600 px Photo storage: 100 max. Mounting: wall
Specifications Intercom panel	Resolution: 3K, 2592 x 1944px Connectivity: 2.4 GHz and 5 GHz IEEE 802.11b/g/n/ ac WiFi Freqs: 2.4GHz / 5GHz Max EIRP: 20dBm Viewing angle: 105° h / 60° v Night vision: invisible IR LEDs Illuminated call button: yes Illuminated label holder: yes Strike plate control: 12 V/1.1 A max. Gate control: breaking capacity 12 V/2 A max. Attachment: surface mounted

Settings	Brightness + contrast + ring volume + colour
Finish	Monitor: grey and black plastic Intercom panel: black and grey aluminium
Electrical features	24V DC - 1A - 24W
Operating temperature	-20°C / +50°C
Use	Monitor: interior intercom panel: exterior (IP54)
Specifications Product alone	Monitor dimensions: 14.9 cm (H) x 19.7 cm (W) x 1.7 cm (D) Intercom panel dimensions: 20.2 cm (H) x 7 cm (W) x 2.8 cm (D) Weight: 800 g
Kit features	Dimensions: 21 cm (H) x 24 cm (W) x 7.8 cm (D) Weight: 1 kg
Standard and certification	CE, RoHS, REACH
Materials	70% recycled ABS monitor Intercom panel: 70% recycled ABS-PC and 100% recycled aluminium

- The warranty is void if parts have been dismantled. Clean the outside with a soft, dry cloth only. Before cleaning, disconnect or switch off the video surveillance system.

#### NOTE

- Do not use any gasoline or carboxylic acid, alcohol or similar treatment. In addition to damaging your device, the fumes are also hazardous to your health and are explosive.
- Do not use any tool that can conduct voltage (wire brush, sharp tool, etc.) for cleaning.

If necessary, consult our technical website:

[www.avidsen.com](http://www.avidsen.com)

Latest version of the downloadable instructions in

colour on: [www.avidsen.com](http://www.avidsen.com)

#### WARRANTY CONDITIONS

- This product is guaranteed for parts and labour in our workshops.
- The warranty does not cover: consumables (batteries, etc.) and damage caused by misuse, improper use, improper installation, external intervention, damage due to physical or electrical shocks, dropping or atmospheric phenomena.
- Do not open the device, as this will void the warranty.
- Clean with a soft cloth only, no solvents. The warranty is void if parts have been dismantled. Clean the outside with a soft dry cloth only. Before cleaning, disconnect the equipment or switch it off at the mains.
- The receipt or invoice is proof of purchase date.

### IMPORTANT!

- Please read the user manual carefully before installing or using this product.
- If you are installing this product for someone else, remember to leave the manual or a copy of it with the end user.

### Warning

- The various items should be dismantled by an authorised technician only.

### Safety measures

- To operate this system in complete safety, it is essential that the installers, users, and technicians follow all of the safety procedures described in this manual.
- Specific warnings and warning symbols are given for items if necessary.
- The product must be set up according to the standards applicable in the country of installation (NF15- 100 for France).
- Damage caused by failing to adhere to the manual nullifies the warranty. We will not accept liability for damage resulting from non-compliance! We will not accept liability for any harm to goods or people caused by improper handling or failure to adhere to safety instructions.

This product was manufactured in total compliance with safety guidelines. In order to maintain this status and provide for the best possible conditions of use, the user must adhere to the safety instructions and warnings in this manual.

This symbol indicates a risk of electrical shock or short-circuiting.

- Only use this product with electrical current in the following ranges: 100-240 Volts and 50-60 Hertz. Never attempt to use this device at a different voltage.
- Ensure that all the system's electrical connections conform to the instructions for use.
- In commercial establishments, be sure to adhere to accident prevention rules for electrical installations.
- For schools, training equipment, workshops, etc., the presence of qualified personnel is needed to monitor operation of the electronic devices.
- Adhere to the usage instructions for other devices connected to the system.

- Contact a person with experience if you are unsure about how to operate the system or about the safety of devices.
- Never plug in or unplug electrical devices with wet hands.
- When installing this product, verify that the power wires are not at risk of being damaged.
- Never replace damaged electrical cables yourself! In this case, remove them and call an expert.

### Warning



This symbol means that devices no longer in use should not be disposed of with household waste. The hazardous substances they may contain can be harmful to health and the environment.



Return the equipment to your local distributor or use the recycling collection service provided by your local council.



Avidsen, undersigned, states that radio equipment such as the Extel Open 3K is compliant with directive 2014/53/EU

Standards:

Directive 2014/35/EU:

EN 62368-1:2020+A11:2020  
EN 62311:2020  
EN 50665:2017

Directive 2014/30/EU:

EN 301489-1 V2.2.3 (2019-11)  
EN 301489-3 V2.3.2 (2023-01)  
EN 301489-17 V3.2.4 (2020-09)  
EN 55032:2015 + A11:2020  
EN 55035:2017 + A11:2020  
EN 61000-3-2:2019 + A1:2021 + A2:2024  
EN 61000-3-3:2013 + A1:2019 + A2:2021

Directive 2014/53/EU:

EN 300328 V2.2.2 (2019-07)  
EN 301893 V2.1.1 (2017-05)  
EN 300440 V2.2.1 (2018-07)

In Tours, 04/02/2025  
Alexandre Chaverot, CEO



**EXT3L**

19 avenue Marcel Dassault  
ZAC des Deux Lions - 37200 Tours - France