

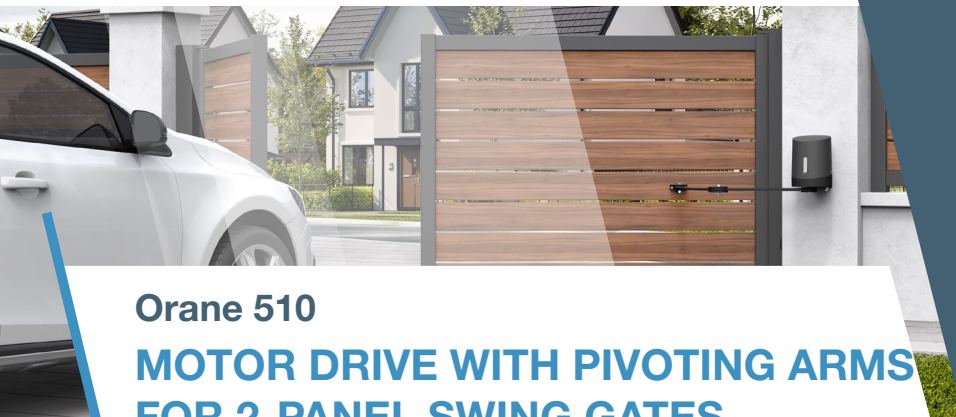

SUPPORT
CALL



GUARANTEE



Orane 510 MOTOR DRIVE WITH PIVOTING ARMS FOR 2-PANEL SWING GATES

Ref. 114201



24V



2,50M
PAR BATTANT



250KG
PAR BATTANT



PORTAIL
BATTANT



COMPATIBLE
AVEC TOUS TYPES



OPTION
SOLAIRE

CONTENTS

A - SAFETY INSTRUCTIONS

1 - OPERATING PRECAUTIONS	04
2 - INSTALLATION PRECAUTIONS	04
3 - MAINTENANCE AND CLEANING	05
4 - RECYCLING	05

B - PRODUCT DESCRIPTION

1 - KIT CONTENTS	06
2 - EQUIPMENT REQUIRED (NOT INCLUDED)	07

C - INSTALLATION

1 - HAZARD ANALYSIS	08
1.1 - Regulations	08
1.2 - Specifications of the gate to motorise	08
1.3 - Safety check on the gate	08
1.4 - Safety rules	09
2 - ELIMINATING HAZARDS	09
2.1 - Subpanels	09
2.2 - Bottom edges	09
2.3 - Between the panels and the fixed parts close to each other	10
2.4 - Preventing other hazards	11

3 - INSTALLING THE MOTOR DRIVE	11
3.1 - Installing the stops	13
3.2 - Assembling the pivoting arm	13
3.3 - Installing the motors - for opening towards the inside of the property	14
3.4 - Installing the motors - for opening towards the outside of the property	20
4 - INSTALLING THE FLASHING LIGHT	25
5 - INSTALLING THE SET OF PHOTOCELLS	26
5.1 - Opening inwards	26
5.2 - Opening outwards	27
5.3 - 2nd set of photocells (optional)	28
6 - CONNECTIONS	30
6.1 - Mains power supply	30
6.2 - Motors	31
6.3 - Flashing light	31
6.4 - Photocells	32
6.5 - Control parts (optional)	33
6.6 - Backup battery (optional)	33
6.7 - Solar power kit (optional)	34



D - BEGINNING OPERATION

1 - SETTINGS INTERFACE	35
2 - BASIC SETTINGS (MENU 1)	35
2.1 - Menu structure	35
2.2 - Photocell alignment procedure (optional)	37
2.3 - Operating mode	37
2.4 - Time delay	37
2.5 - Motor force	38
2.6 - Speed	38
2.7 - Self-learning	38
2.8 - Programming remote controls	41
3 - ADVANCED SETTINGS	41
3.1 - Access to advanced settings (MENUS 2 and 3)	42
3.2 - Advanced settings menu (MENU 2)	42
3.3 - Advanced settings menu (MENU 3)	44

E - USE

1 - WARNINGS	46
2 - OPENING/CLOSING	46
3 - TYPE OF COMMAND	46
4 - OPERATING MODE	46
4.1 - "Semi-automatic closing" mode	47
4.2 - "Automatic closing" mode	47
4.3 - "Collective" mode	47

5 - PHOTOCELLS	48
5.1 - Obstacle detection	48
6 - MANUAL MOVEMENT	48

F - MAINTENANCE AND UPKEEP

1 - MAINTENANCE WORK	49
2 - OPERATING INDICATORS	50
2.1 - History of events and error codes	50
2.2 - Manual control	51
2.3 - Total reset	52
2.4 - Replacing the remote control battery	52
2.5 - Replacing the power fuse	53

G - TECHNICAL AND LEGAL INFORMATION

1 - COMPATIBLE ACCESSORIES	54
2 - TECHNICAL FEATURES	54
3 - WARRANTY	56
4 - HELP AND ADVICE	56
5 - PRODUCT RETURNS - AFTER-SALES SERVICE	57
6 - DECLARATION OF CONFORMITY	57

A - SAFETY INSTRUCTIONS

In our efforts to continually improve our products, we reserve the right to make any changes to the technical, functional or aesthetic characteristics related to their development.

This automatic gate opening mechanism, and its manual, were designed to enable a gate to be motorised in compliance with current European standards.

WARNING

Important safety instructions. A automatic gate opening mechanism is a product that can cause injury to people and animals and damage to property. It is important for people's safety to follow these instructions and keep them.

1 - OPERATING PRECAUTIONS

- This device may be used by children over the age of 8 and by persons with reduced physical, sensory or mental abilities or lack of experience or familiarity, if they are correctly supervised or if the instructions relating to the safe use of the apparatus have been given to them and the possible hazards are understood. Children must not play with the device. Keep the remote controls out of the reach of children. Cleaning and maintenance must not be conducted by children without supervision.
- This device should only be used for its intended purpose, that is, to motorise a one- or two-panel gate for vehicle access. Any other use will be considered dangerous.
- The opening or closing manoeuvre control must be used with perfect visibility of the gate. Should the gate be outside the user's field of vision, the installation must be protected by a photocell type safety device, and its operation must be checked every six months.
- All potential users must be instructed in the use of the motorised gate by reading this manual. It must be ensured that no persons who have not been instructed in the use of the device may set the gate into motion.
- Before setting the gate into motion, ensure that there is no person in the area in which the gate moves.
- Avoid any natural obstacles (branch, stone, high grass, etc.) impeding the gate's movement.
- Do not manually activate the gate when the motor drive is not disengaged from the gate.
- Avidsen cannot be held liable for any use that does

not comply with the instructions in this manual and causes damage.

2 - OPERATING PRECAUTIONS

- Read this entire manual before starting the installation.
- The electrical installation of the motorised gate must meet current standards (in particular NF C 15-100) and should be undertaken by a qualified person.
- The 230 V mains supply must be protected with a suitable circuit breaker which meets current standards.
- All electrical connections must be performed with the power switched off (safety switch in OFF position) and battery disconnected.
- Ensure that crushing and shearing between the mobile parts of the motorised gate and the surrounding fixed parts due to the gate's opening/closing movement are avoided or signalled on the installation.
- The motorised part must be installed on a gate according to the specifications provided in this manual.
- The motorised gate must not be installed in an explosive atmosphere (presence of gas, flammable smoke, etc.).
- The installer must check that the temperature range shown on the motor drive is suitable for the location.
- The wire that acts as an antenna must remain inside the electronic panel.
- It is strictly forbidden to modify any of the components provided in this kit, or to use an additional component not provided for in this manual.
- During installation, but above all during adjustment of the motorised gate, you must ensure that no person, including the installer, is in the area in which the gate moves at the start and throughout the duration of adjustment.
- The flashing light is an essential safety component.
- If installation does not correspond to one of the cases shown in this manual, you must contact us so that we can provide all the components necessary for smooth installation with no risk of damage.
- After installation, ensure that the mechanism is correctly adjusted and that the protection systems as well as the manual override device work correctly.
- Do not let children play with the fixed control devices. Keep the remote controls out of the reach of children.

A - SAFETY INSTRUCTIONS

- Avidsen cannot be held liable in case of damage if installation is not conducted as indicated in these instructions.

3 - MAINTENANCE AND CLEANING

- Read all the instructions given in this manual before carrying out maintenance on the motorised gate.
- Disconnect the power supply during cleaning or maintenance operations, in particular if the device is automatically controlled.
- Any technical, electronic or mechanical change to the motorised gate must be made with our technical department's approval. Otherwise, the guarantee will be immediately cancelled.
- In the event of breakdown, the damaged part should be replaced by an original part and nothing else.
- Check the installation frequently to reveal any fault on the gate or the motor drive (see the chapter on maintenance).
- Never use abrasive or corrosive substances to clean the product.
- Do not clean the product with a pressure washer.
- Use a soft, slightly damp cloth.
- Do not use aerosol sprays on the product because they could damage its interior.
- Regularly check the lubrication of all the joints of the automatic gate opening mechanism and of the gate.

4 - RECYCLING



Disposing of used batteries in household waste is strictly forbidden. Batteries/accumulators containing harmful substances are marked with symbols (shown opposite) which indicate that it is forbidden to discard them in the household waste. The heavy metals are referred to as follows: Cd = cadmium, Hg = mercury, Pb = lead.

You can dispose of these used batteries/accumulators at local waste facilities (centres for sorting recyclable materials), which are required to accept them. Keep batteries/button cells/accumulators out of reach of children and store them in a safe place not accessible to them. They could be swallowed by children or pets. May be fatal if swallowed! In the event that a battery is swallowed, consult a doctor or go to A&E immediately.

Never short-circuit the batteries, and do not burn or recharge them. They may explode!



This logo denotes that devices which are no longer in use must not be disposed of as household waste. The hazardous substances they may contain can be harmful to health and the environment. Return the equipment to your local distributor or use the recycling collection service provided by your local council.



Pour en savoir plus :
www.quefairedemesdechets.fr

B - PRODUCT DESCRIPTION

1 - KIT CONTENTS

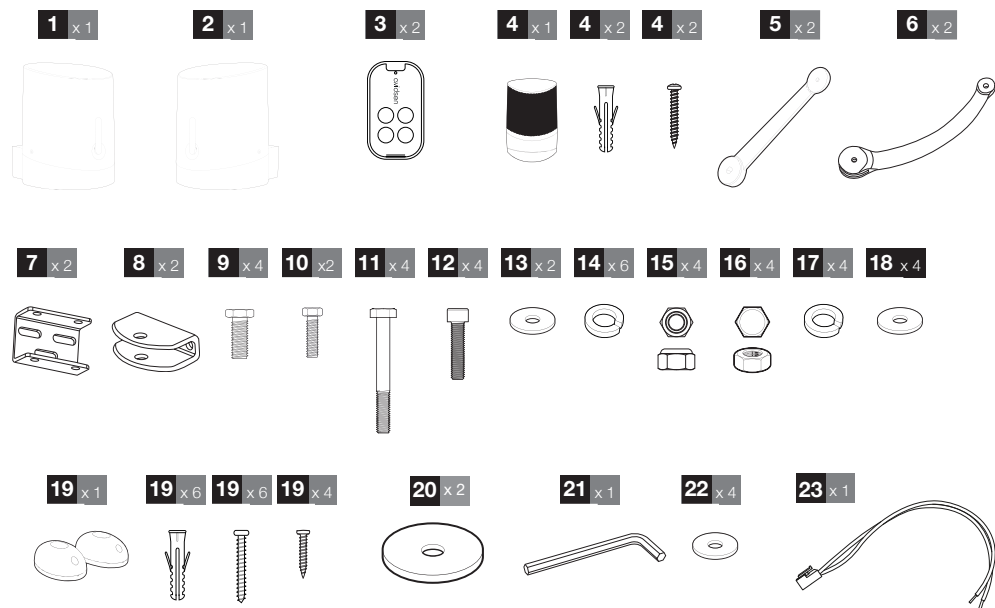

1	Main motor with electronic card
2	Secondary motor
3	Remote control
4	Flashing light and screws
5	Rear arm
6	Front arm
7	Post mounting bracket
8	Gate mounting bracket
9	M12 – L40 screw
10	M8 – L25 screw
11	M10 – L90 screw

12	M8 CHC – L30 screw
13	M8 washer
14	M8 spring washer
15	M12 locknut
16	M10 nut
17	M10 spring washer
18	M10 washer
19	Photocells and their screws
20	Oversized M8 washer
21	Allen key
22	M12 washer
23	Solar kit connector

2 - EQUIPMENT REQUIRED (NOT INCLUDED)

The tools and screws required for the installation must be in good condition and compliant with applicable safety standards.

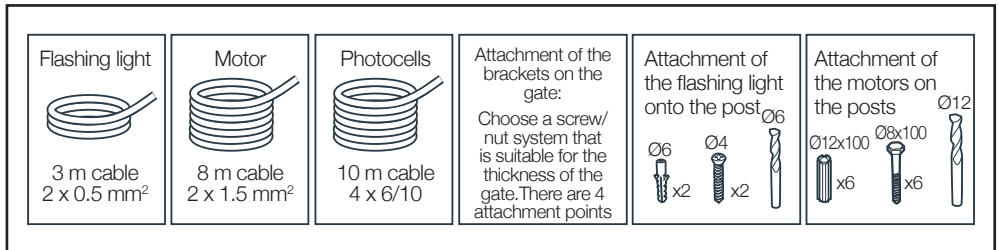
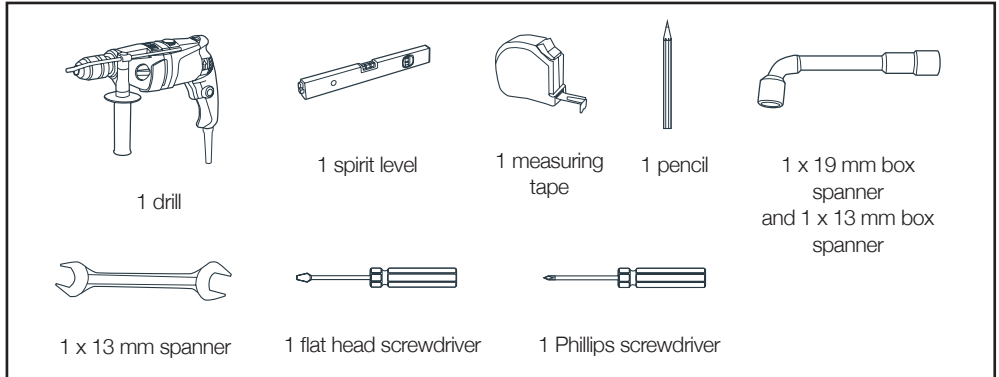

1. HAZARD ANALYSIS

1.1. Regulations

Installation of a motorised gate or a motor drive on an existing gate within the framework of "Residential" type use must be compliant with directive 89/106/EEC concerning building products.

The reference standard used to check this compliance is EN 13241-1 which refers to a framework of several standards including EN 12445 and EN 12453 which specify the motorised gate safety methods and components to reduce or completely eliminate hazards to people.

The installer must train the end user on the correct operation of the motorised gate, and the trained user must train the other people likely to use the motorised gate, using this guide.

It is specified in standard EN 12453 that the minimum protection of the gate's primary edge depends on the type of use and the type of control used to set the gate in motion.

The gate motor drive is a press control system, i.e. simply pressing one of the control parts (remote control, key selector, etc.) sets the gate in motion.

This gate motor drive is equipped with a force limiter which complies with appendix A of EN 12453 standard, within the framework of use with a gate that is compliant with the specifications given in this chapter. The specifications of EN12453 standard therefore enable the 3 following use cases, as well as the minimum levels of protection:

- Press activation with visible gate
 - Force limiter only.
- Press activation with non-visible gate
 - Force limiter and 2 pairs of photocells to protect the gate's opening and closing.
- Automatic control (automatic closing)
 - Force limiter and 1 pair of photocells to protect the gate's automatic closing

The flashing light is an essential safety component.

The photocell type safety devices and their correct operation must be checked every six months

1.2. Specifications of the gate to motorise

This motor drive can automate swing gates up to **2.50m** wide and **2.80m** high and weighing **250kg**.

These maximum dimensions and weights are for an

openwork-type gate and for use in an area that is not very windy. **For solid gates or a use in an area with significant wind speed, it is necessary to reduce the maximum values indicated above for the gate to be motorised.**

1.3. Safety checks on the gate

The motorised gate is strictly for residential use. The gate must not be installed in an explosive or corrosive atmosphere (presence of gas, flammable smoke, vapour or dust).

- The gate must not have locking systems (latch, lock, bolt, etc.).
- The hinges of the gate must be on the same axis and the axis must be vertical.
- The posts supporting the gate must be strong and stable enough so that they do not bend (or break) under the weight of the gate.
- Without the motor drive, the gate must be in good mechanical conditions, correctly balanced and open and close without friction or resistance.
- Greasing the hinges is recommended. Check that the fastening points of the different components are in locations that are sheltered from shock and that the surfaces are solid enough.
- Check that the gate does not have any part protruding from its structure. The central stop and side stops must be appropriately fastened so as not to give way under the force exerted by the motorised gate.

If installation does not correspond to one of the cases shown in the guide, contact us so that we can provide all the components necessary for proper installation with no risk of damage.

The motor drive cannot be used with a driven part that has a door.

1.4. Safety rules

The actual opening of a gate may create dangerous situations for people, goods and vehicles in the vicinity that by nature, cannot always be avoided by design.

The possible hazards depend on the state of the gate, the manner in which it is used and the installation site. After having checked that the gate to be motorised complies with the requirements given in this chapter

and before beginning the installation, a hazard analysis of the installation must be conducted in order to eliminate all dangerous situations or to indicate them if they cannot be eliminated.

2. ELIMINATING HAZARDS

The hazards posed by a two-panel motorised gate, as well as the adapted solutions to eliminate those hazards, are as follows:

2.1. Subpanels

Following installation, there may be a shear zone between the panel and the corner of the post. In this case, it is recommended to remove this zone leaving a minimum working distance of 25mm either by positioning the side stops accordingly or by notching the corner of the posts without weakening them, or both if necessary.

If this is not possible, the hazard must be clearly indicated

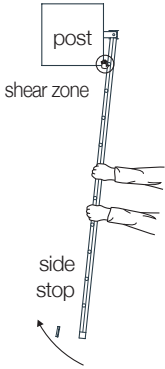
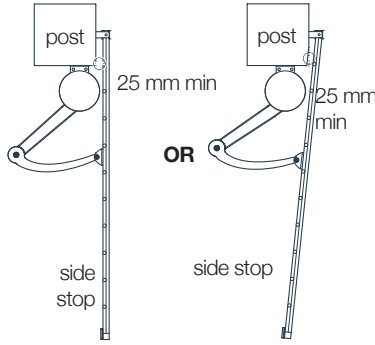
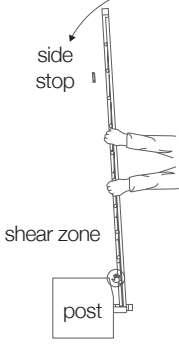
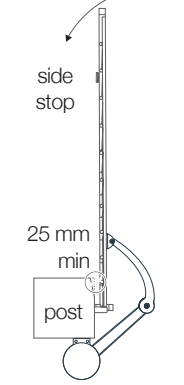
For opening towards the inside		For opening towards the outside	
Hazard	Solution	Hazard	Solution
 <p>post</p> <p>shear zone</p> <p>side stop</p> <p>view from above</p>	 <p>post</p> <p>25 mm min</p> <p>OR</p> <p>25 mm min</p> <p>side stop</p> <p>view from above</p>	 <p>side stop</p> <p>shear zone</p> <p>post</p> <p>view from above</p>	 <p>side stop</p> <p>25 mm min</p> <p>post</p> <p>view from above</p>

C - INSTALLATION

2.2. Bottom edges

Following installation, there may be a dangerous zone for toes between the bottom edge of the gate and the ground, as indicated in the following figure.

In this case, this area must be removed leaving a working distance of minimum 50mm or maximum 5mm.

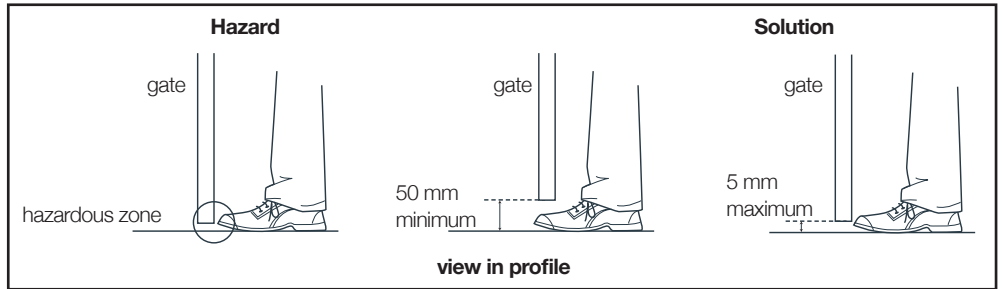

2.3. Between the panels and the fixed parts close to each other

Depending on the configuration of the site where the motorised gate is installed, there may be confinement areas between the panels in open position and the fixed parts close to them. To remove these areas, it is mandatory to leave a safe distance of 500mm between the fixed part and the moving parts of the motorised gate.

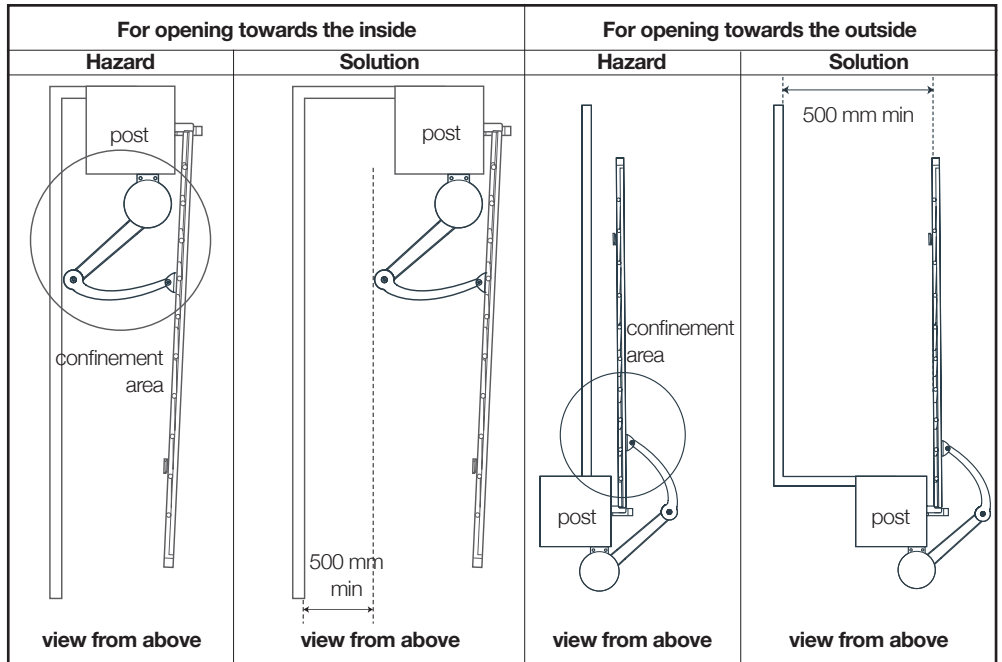

2.4. Preventing other hazards

The body of a switch with no lock must be located in direct view of the driven part but away from moving parts. Unless it operates with a key, it must be installed at a minimum height of 1.5m and must not be accessible to the public.

After installation, ensure that the components of the gate do not hang above a footpath or public access road.

3. INSTALLING THE MOTOR DRIVE

The motor drive must be installed by qualified personnel, in compliance with all the indications provided in the “General warnings.”

Before starting installation, ensure that:

- Hazards can be minimised by following the recommendations under the Chapter “Hazard analysis.”
- The desired use has been correctly defined.
- The gate complies with the specifications provided in the Chapter “Specifications of the gate to motorise.”

The different stages of installation must be followed in order and in compliance with the indications given.

Overview

The cables used must be appropriate for outdoor use (such as H07RN-F for example).

The cable run between the two posts must comply with applicable standards (NFC 15-100).

The geared motor power cable must run 80 cm deep with red warning mesh.

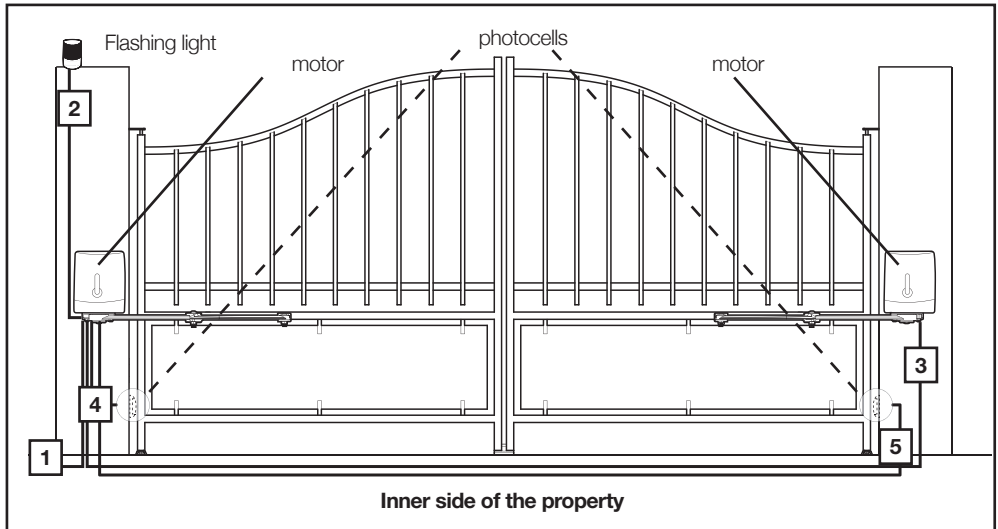

Tip: Position the motor containing the electronic card on the post where the 230V electrical supply is located. If the 230V electrical supply is already located on the left post, the connections do not need to be reversed. If the electrical supply is located on the right post, it is sufficient to reverse the motor connection polarity in order to reverse the direction of rotation with respect to the assembly described in these instructions (normal mounting with motor and electronic card on the left).

C - INSTALLATION

List of cables:

	Connection	Cable	Max length
1	230 VAC power line	Cable 3 x 2.5 mm ² (more than 30 m long) Cable 3 x 1.5 mm ² (less than 30 m long)	Unlimited
2	Flashing light	Cable 2 x 0.5 mm ²	15 m
3	Secondary motor	2 x 1.5 mm ² cable	10 m
4	Reception photocell (RX)	4 x 6/10 cable	10 m
5	Transmission photocell (TX)	4 x 6/10 cable	10 m

3.1. Installing the stops

This gate motor drive is a self-locking motorisation system. Your 2-panel gate must be equipped with a central stop and side stops (not included).

The (central and side) stops must stop the gate without locking it. In other words, any mechanical lock (or latch) and any tilting shoe base or stopper must be removed.

3.1.1. - For opening towards the inside of the property

The installation of the side stops depends on the desired opening angle which depends on distance D (the distance between the axis of the hinge and the inner side of the post).

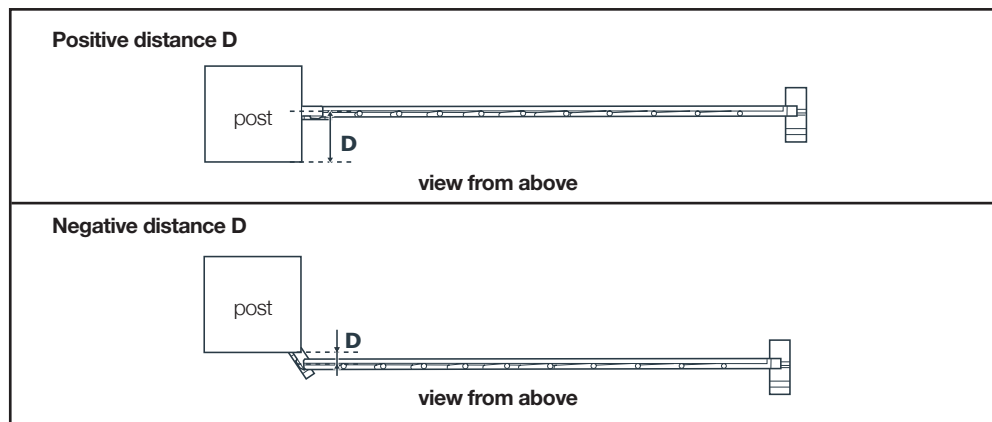

If the positive distance **D** is greater than 200 mm or if distance **D** is negative, the configuration of the posts must be adjusted.

Determine the opening angle of each panel based on the data in the following table.

The opening angle may be different for each panel but must never be less than 40°.

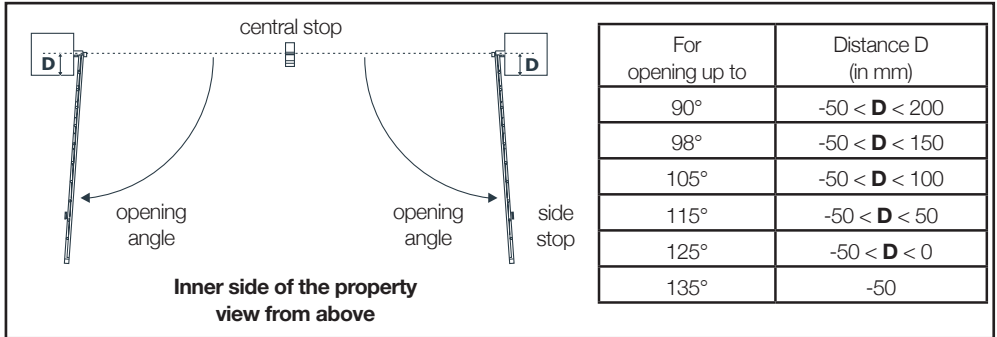

3.1.2. - For opening towards the outside of the property

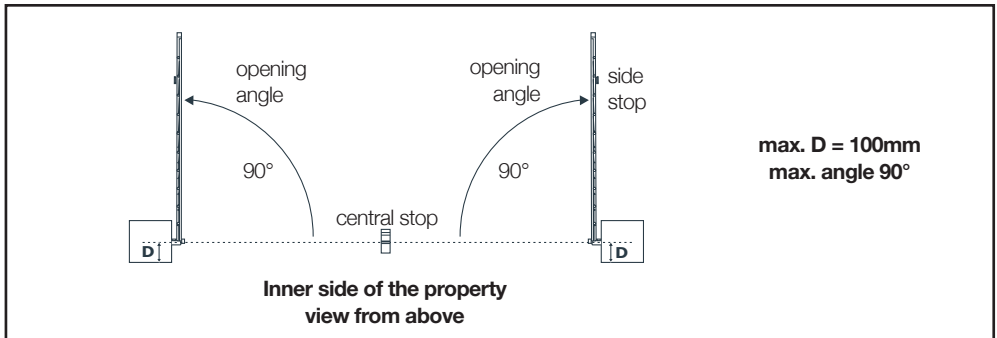

3.2. Assembling the pivoting arm

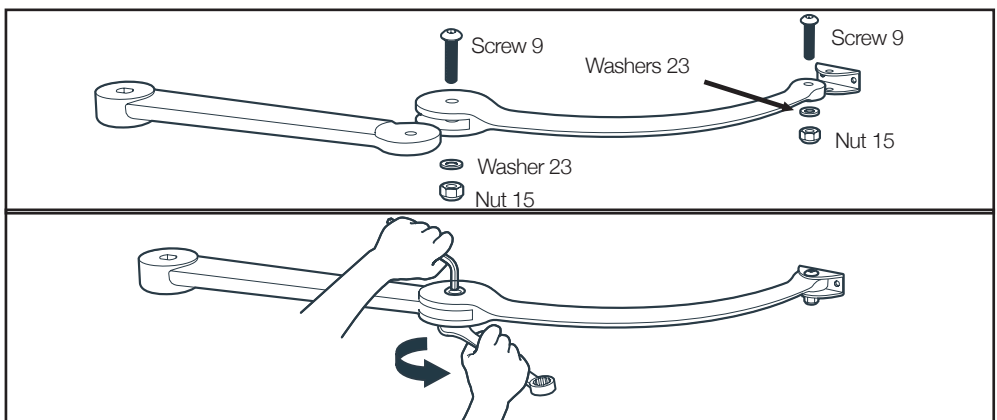

Please note: do not overtighten the parts together, the different pivoting parts must be able to turn freely.

C - INSTALLATION

3.3 - Installing the motors - for opening towards the inside of the property

- Place the mounting brackets against the posts, 14mm above the rigid part of the gate where the ends of the pivoting arms will be fastened.

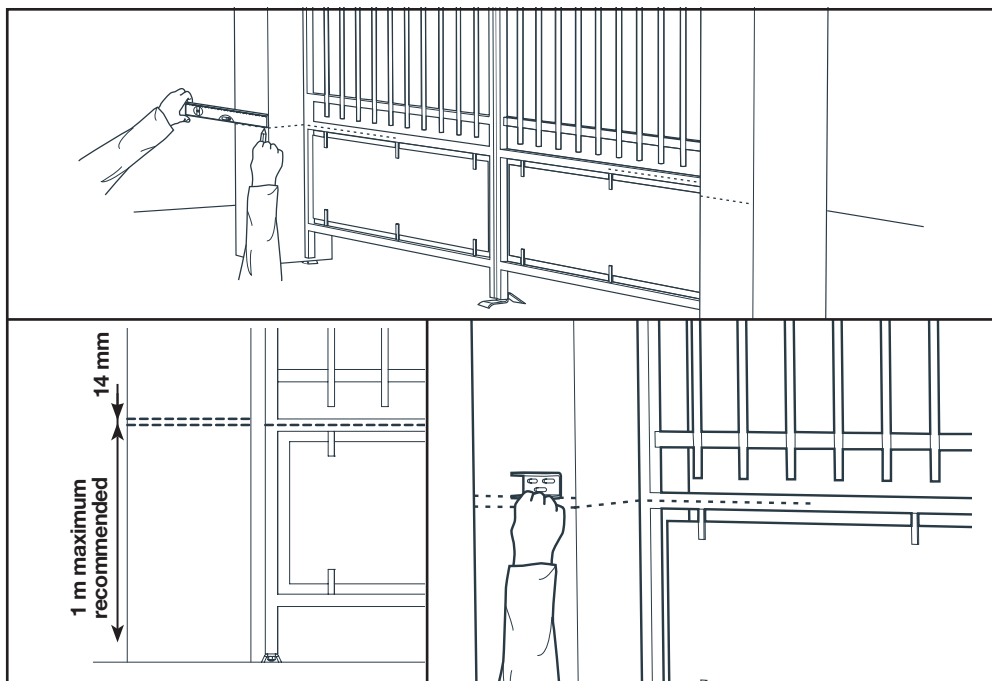

- Use plugs and screws that are suitable for the post material (example: for concrete, use $\varnothing 12\text{mm}$ plugs and $\varnothing 8\text{mm}$ lag screws with a length of 80mm). After tightening, the mounting bracket must be completely horizontal and 14mm above the middle of the rigid part of the gate. Make sure not to weaken the posts.

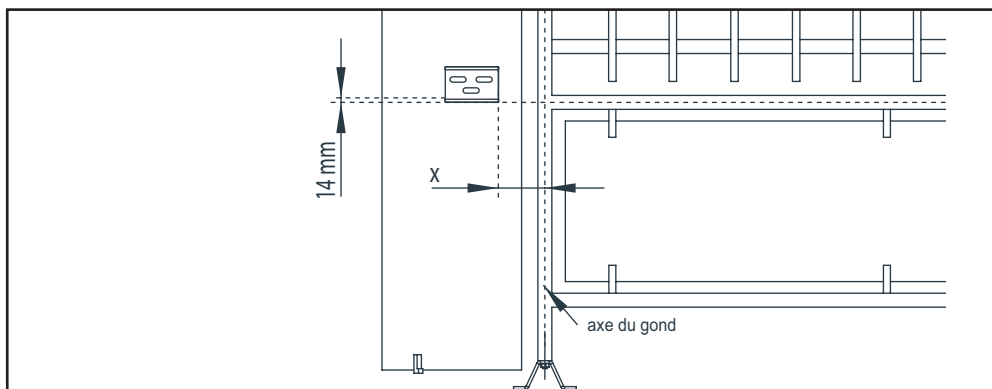

- Depending on the maximum opening angle desired for the gate, the post bracket should be placed further from or nearer to the edge of the post (so that the motor does not prevent the gate from opening). For optimum motor operation, the distance **X** must be as small as possible. Also note that a 25mm safety distance is required between the open gate and the motor (**see Chapter "Hazard Analysis"**). Temporarily place the motor on the ground in position and search for the correct position to determine distance **X**.

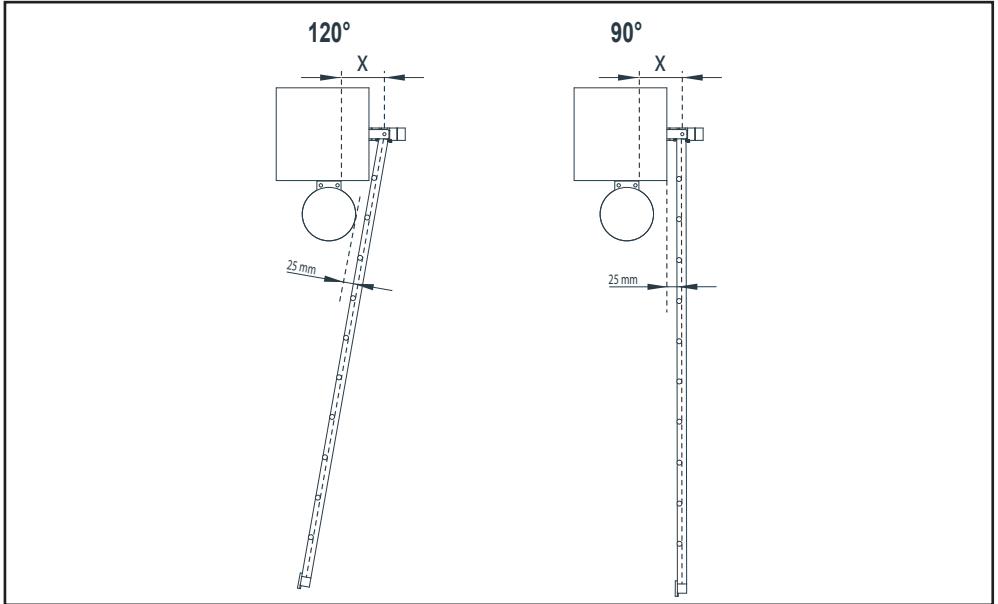

- Position the bracket on the post (using distance **X**) and mark the locations of the holes. To position the motor unit as close as possible to the gate, while respecting the safety distance, use distance **X**. The closer the motor unit is to the edge of the gate, the better the grip of the arms on the gate.

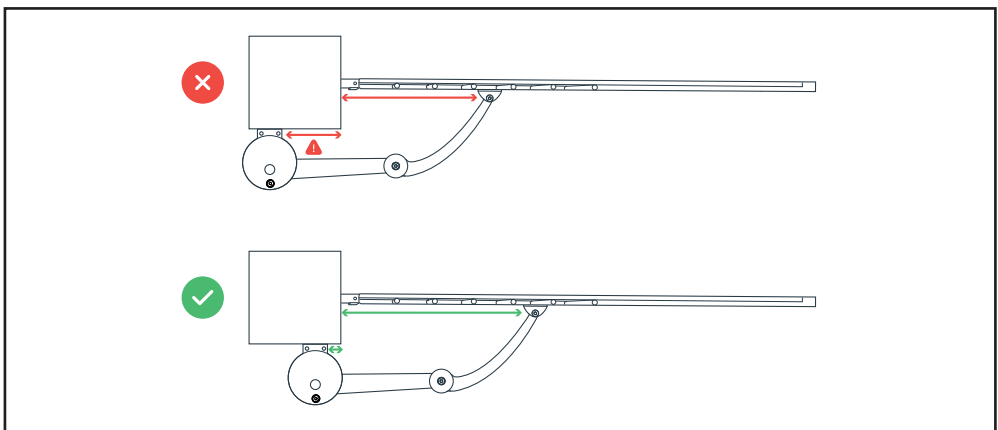

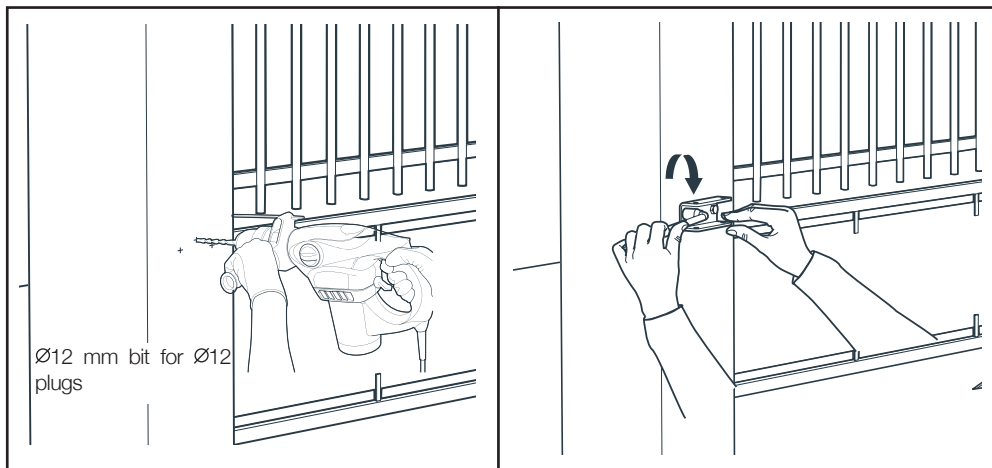
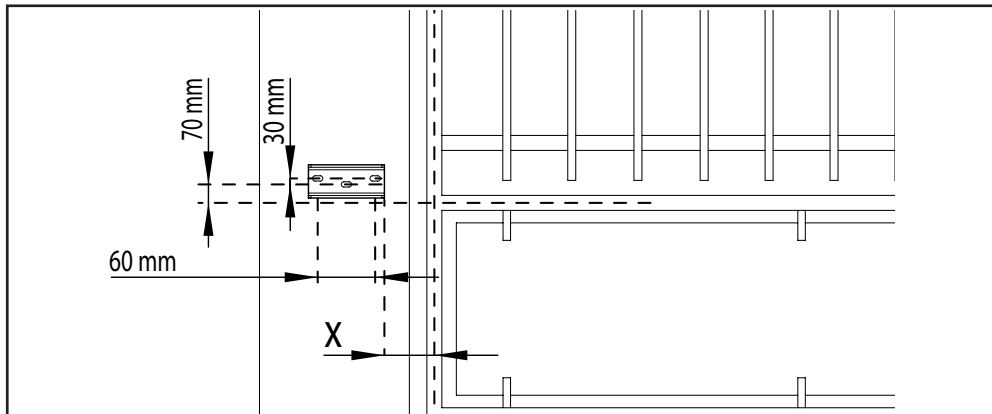

- Open the cover of the motors

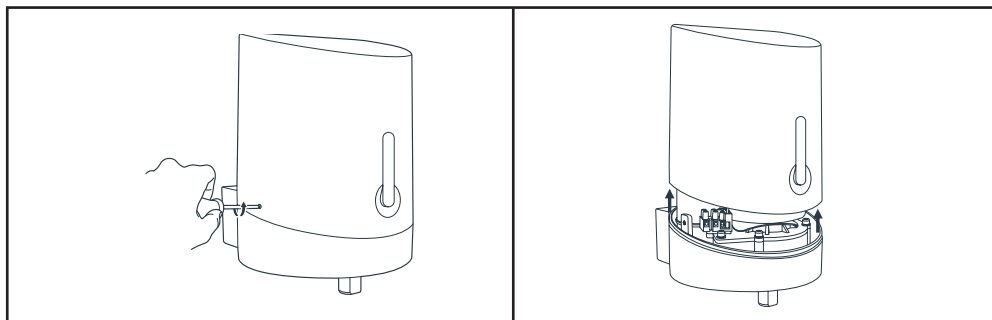

- Fasten the motors on the mounting brackets

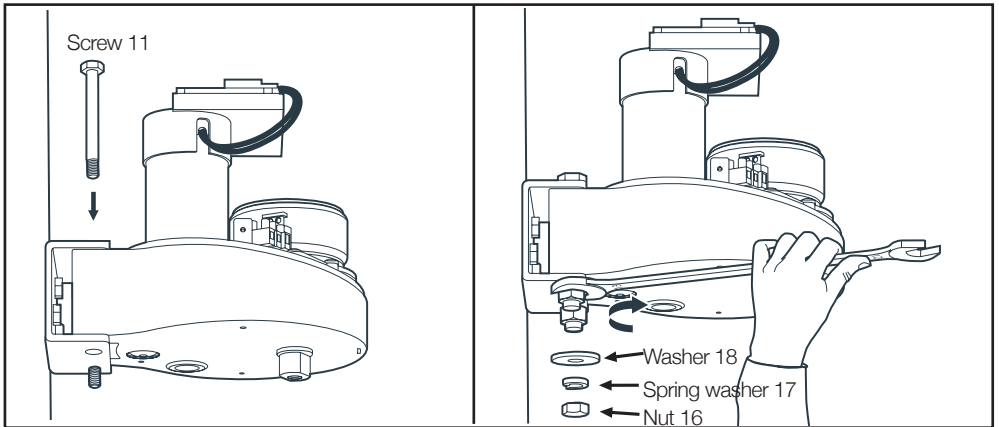
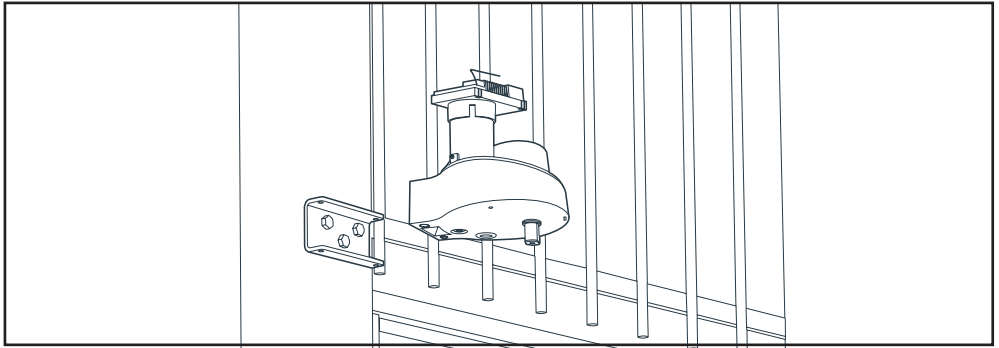

- Assemble the pivoting arms and motors

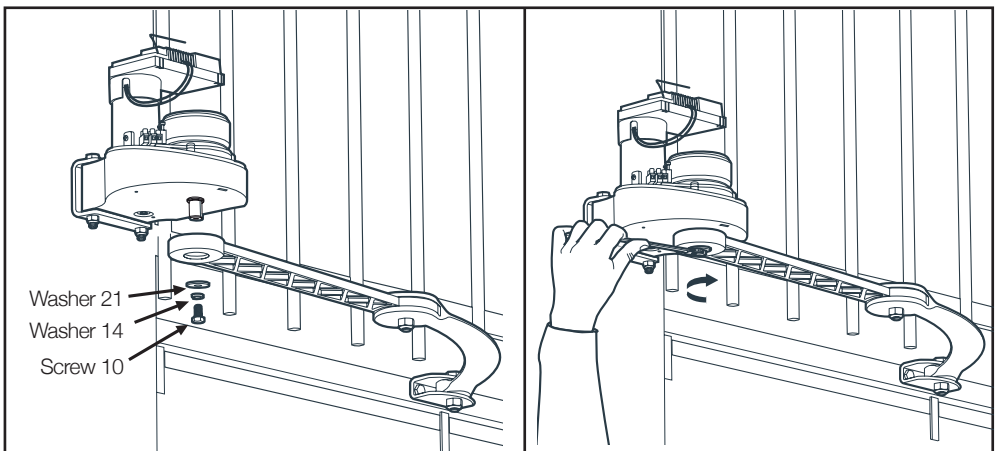

C - INSTALLATION

- Motor disengagement

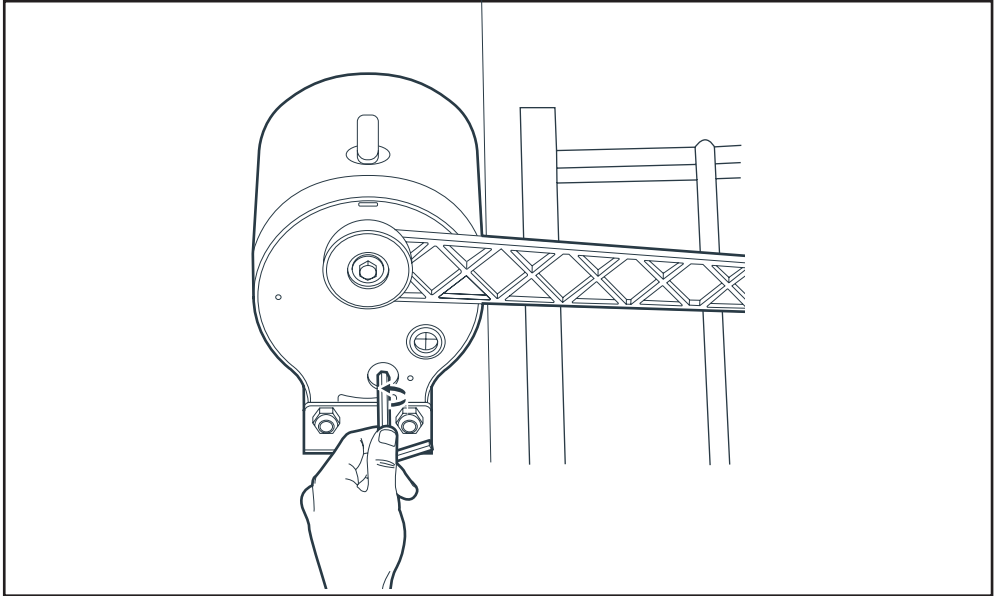

- Disengage the motors in order to manually manoeuvre the arms

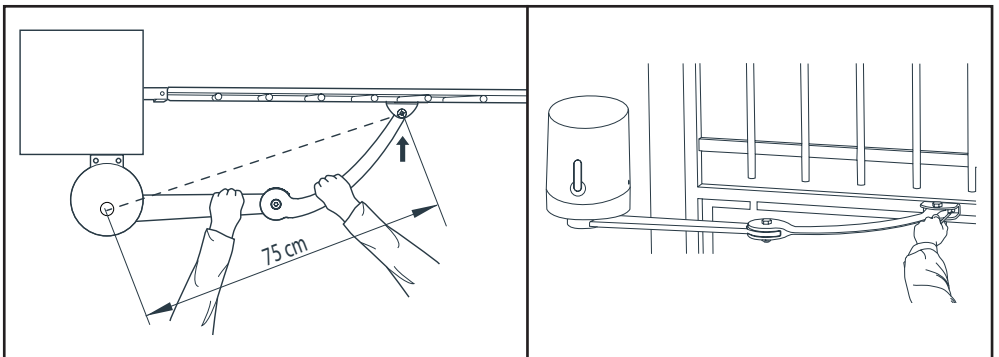

- Close the gate by pressing it firmly against the central stop.
- Position the pivoting arms against the gate at a distance of 75cm and mark the location of the holes on the gate.

Important: The ends of the right arms should be at the middle of the rigid part of the gate so that the pivoting arms are completely horizontal.

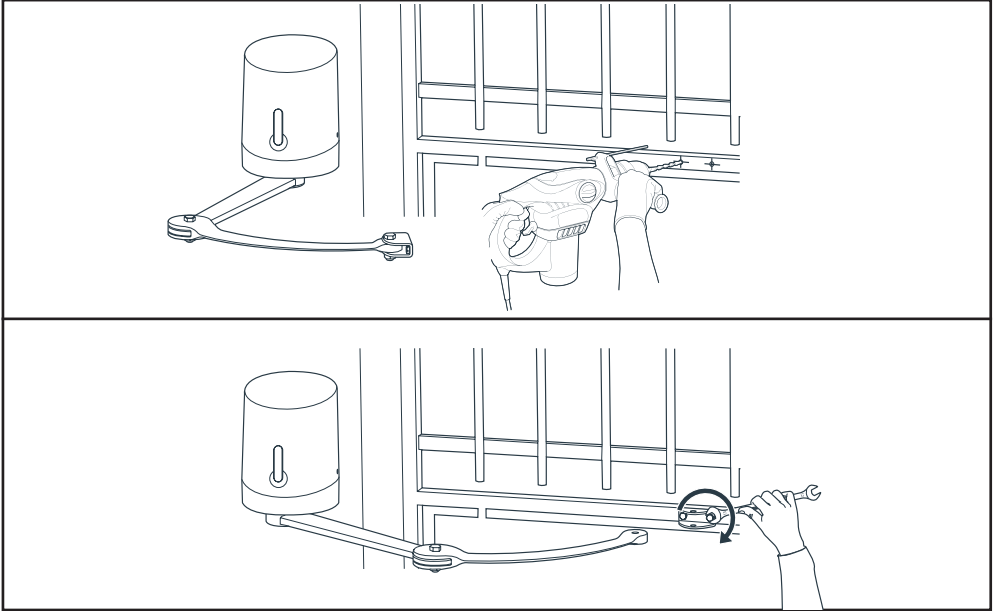

- Remove the gate bracket from the arm in order to fasten it to the gate.
- Use screws and nuts that are suitable for the gate material.
- Reassemble the end of the arm and the gate bracket.

Important: At this point in the installation, the motors are disengaged. The gate may be set in motion by the wind or an external push. Be careful or block the gate to avoid any hazards during the rest of the installation.

→ Or engage the motors:

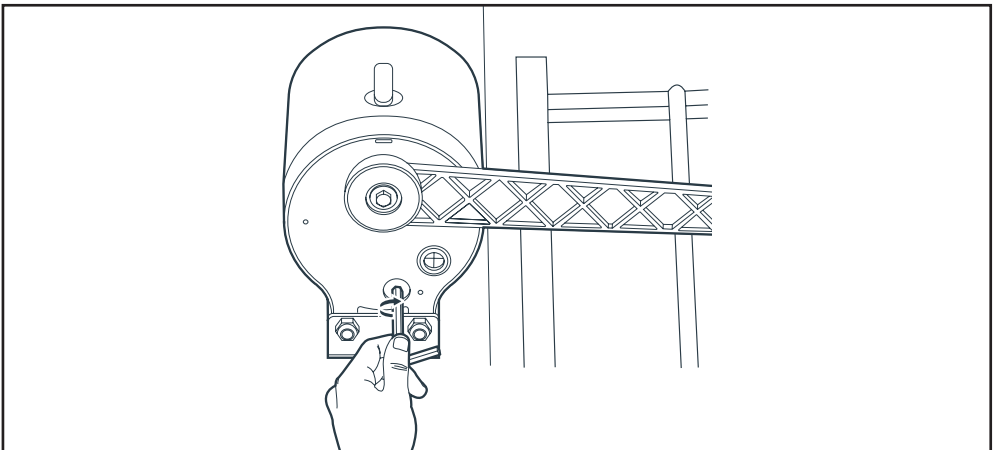

C - INSTALLATION

3.4 - Installing the motors - for opening towards the outside of the property

- Place the mounting brackets against the posts, 14mm above the rigid part of the gate where the ends of the pivoting arms will be fastened.

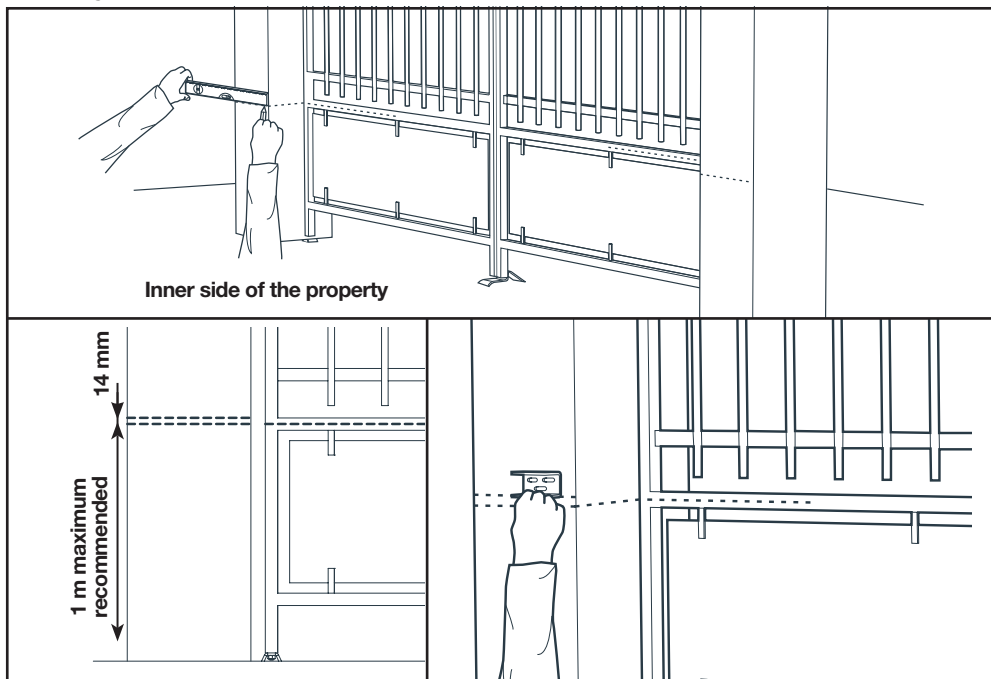

- Use plugs and screws that are suitable for the post material (example: for concrete, use $\varnothing 12\text{mm}$ plugs and $\varnothing 8\text{mm}$ lag screws with a length of 80mm). After tightening, the mounting bracket must be completely horizontal and 14mm above the middle of the rigid part of the gate. Make sure not to weaken the posts.

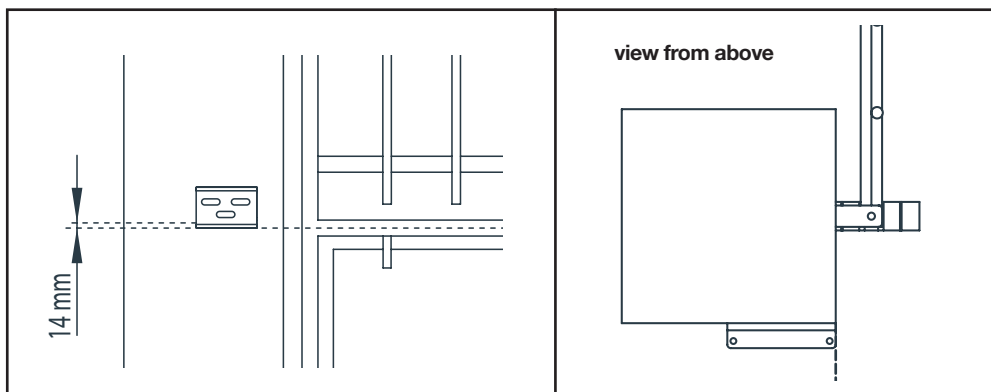

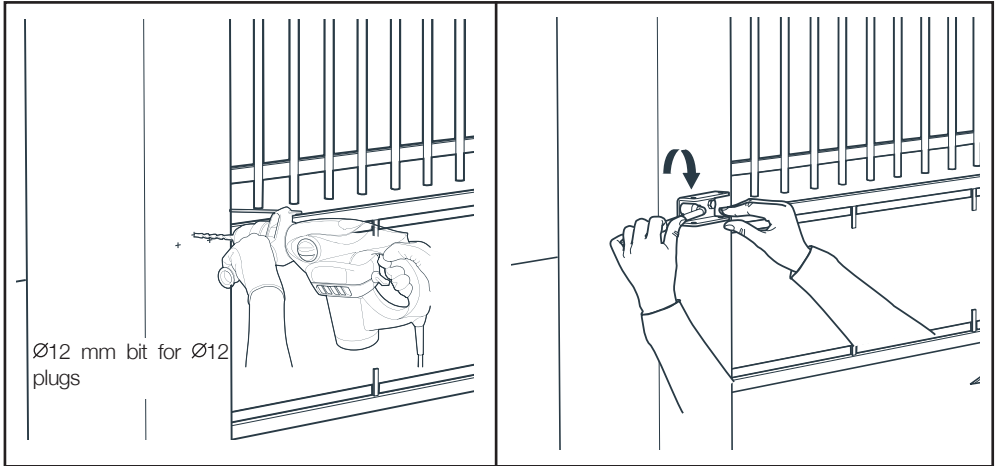
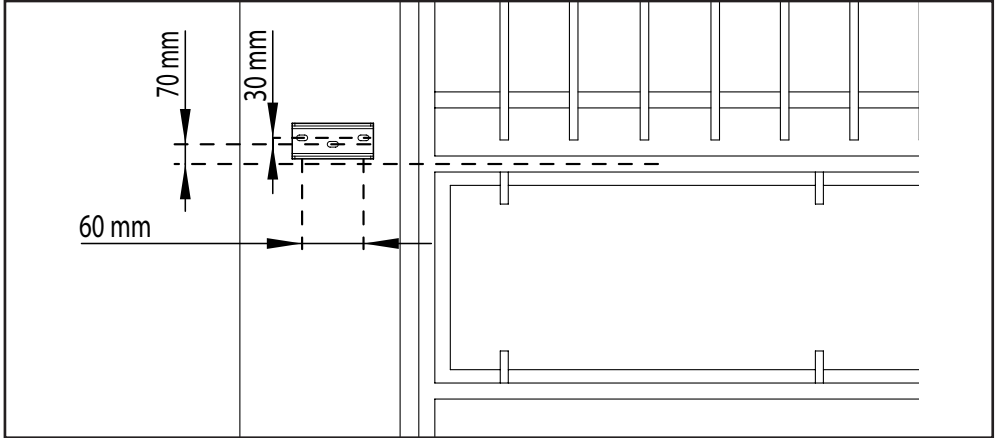

- Open the cover of the motors

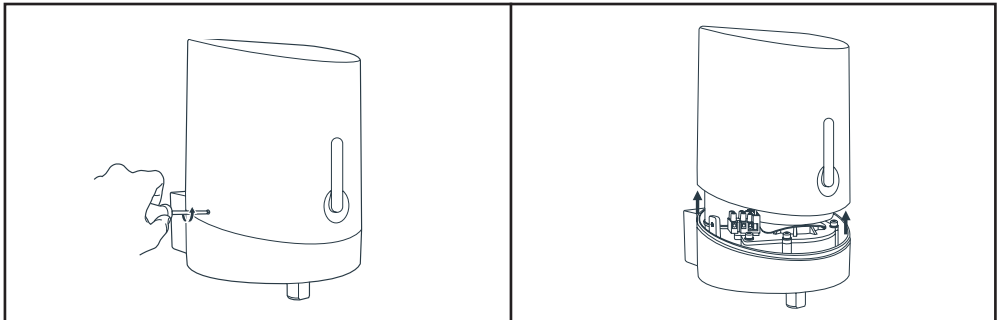

C - INSTALLATION

- Fasten the motors on the mounting brackets

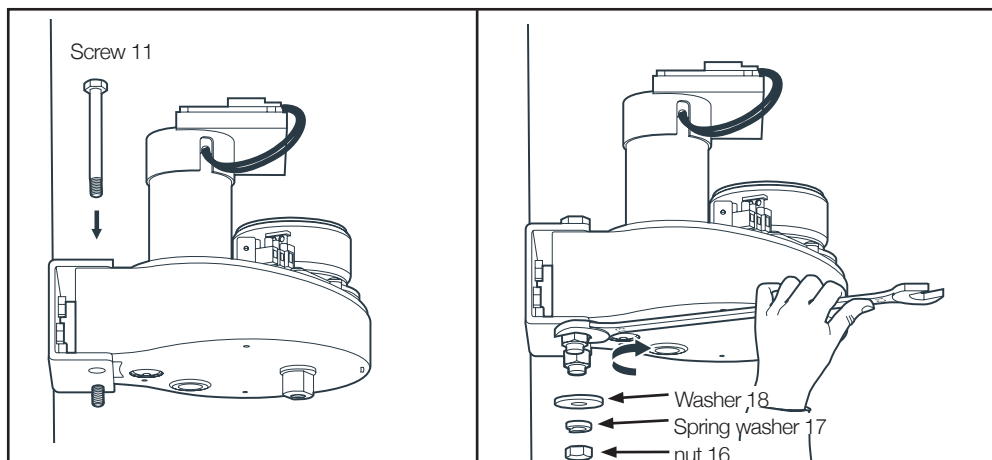
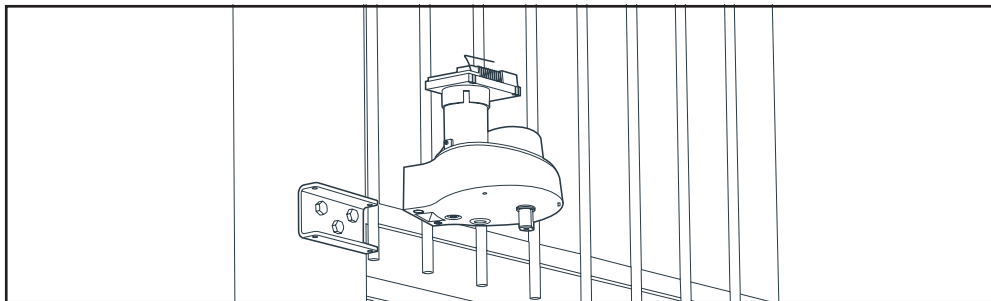

- Assemble the pivoting arms and motors

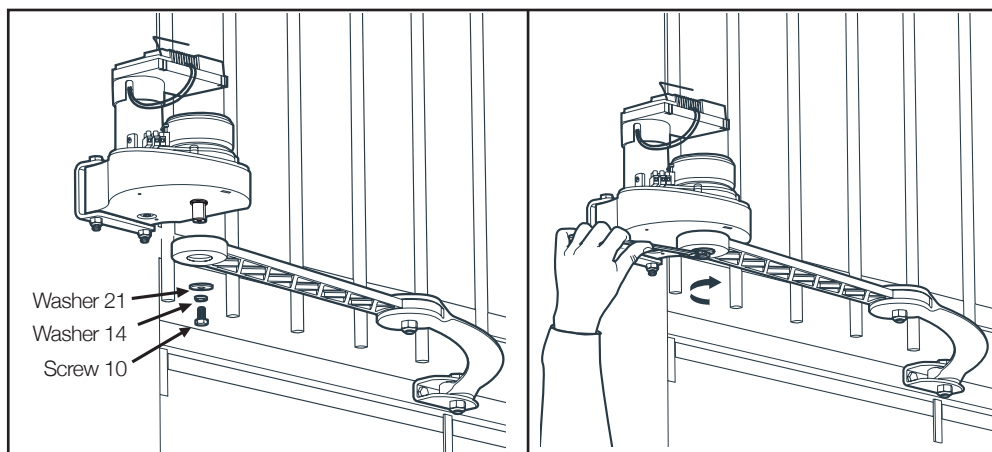

- Motor disengagement

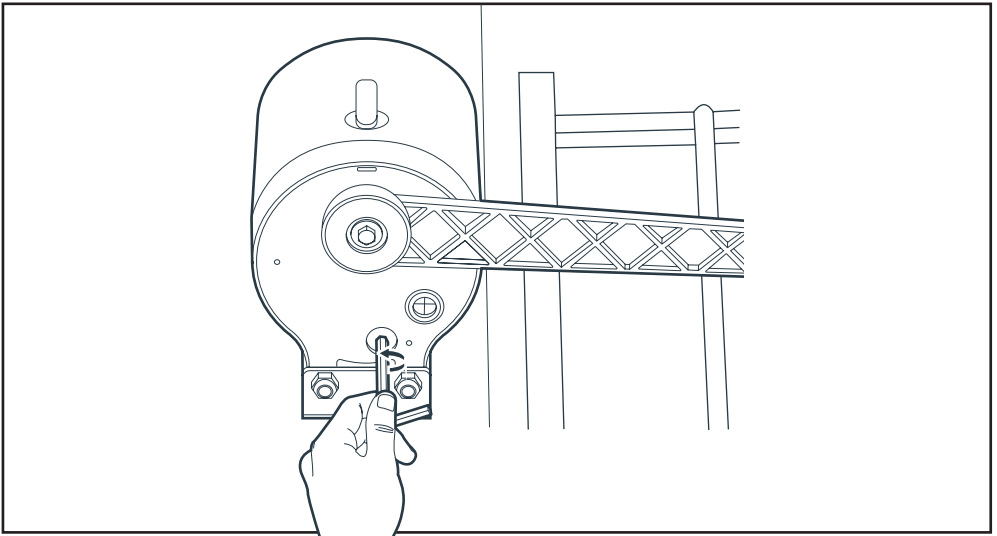

- Disengage the motors in order to manually manoeuvre the arms.
- Open the gate up to the side stops.
- Turn the pivoting arm to press the gate bracket against **the gate as far as possible from the hinges:**

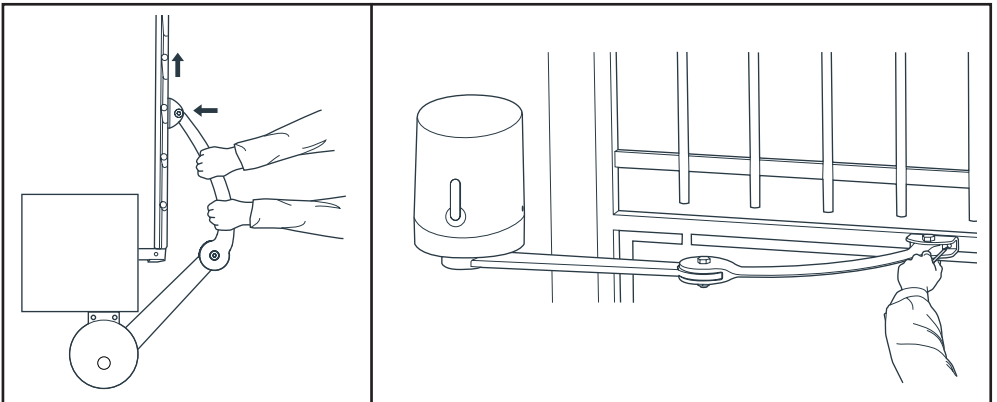

- Mark the holes for fastening the bracket on the gate.

C - INSTALLATION

Important: The ends of the right arms should be at the middle of the rigid part of the gate so that the pivoting arms are completely horizontal.

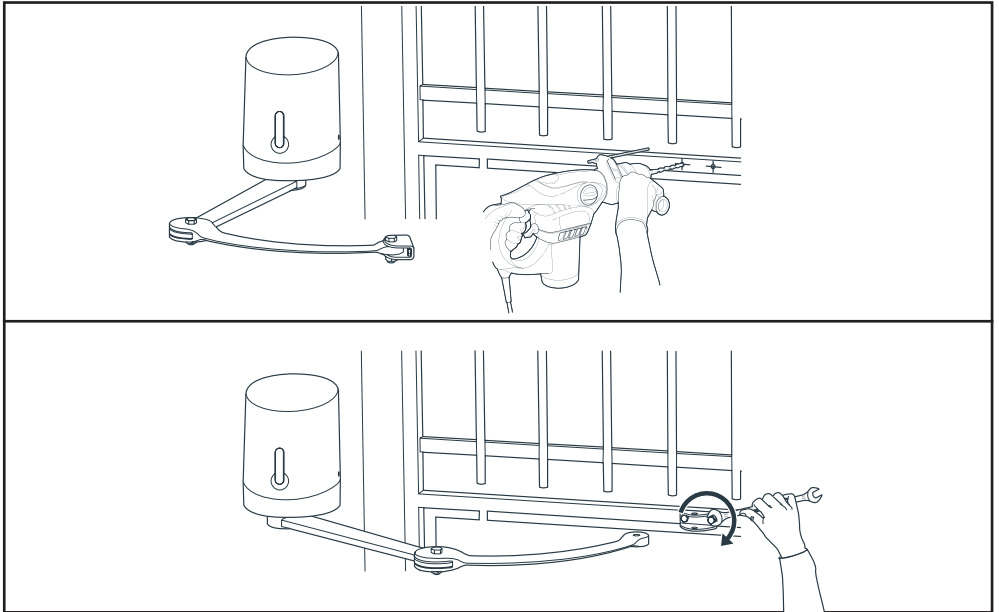

- Remove the gate bracket from the arm in order to fasten it to the gate.
- Use screws and nuts that are suitable for the gate material.
- Reassemble the end of the arm and the gate bracket

Important: At this point in the installation, the motors are disengaged. The gate may be set in motion by the wind or an external push. Be careful or block the gate to avoid any hazards during the rest of the installation.

→ Or engage the motors:

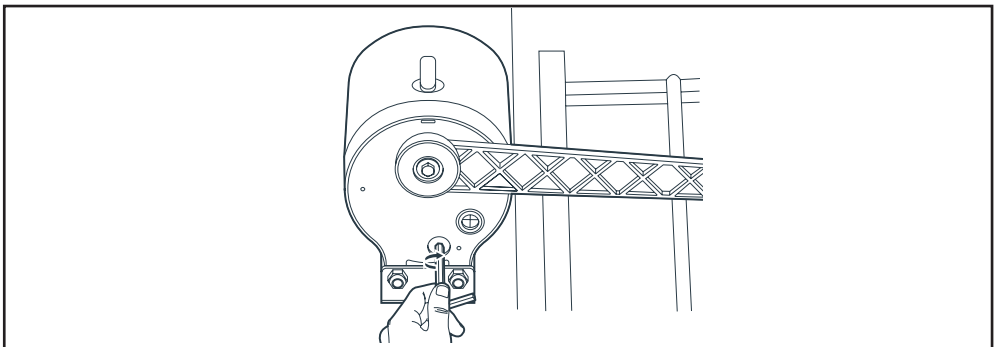

4. FLASHING LIGHT INSTALLATION

The flashing light must be fastened at the top of the post on which the switchgear is attached and must be visible both inside and outside. Only use the light provided in the kit (24 V - 2 W).

The flashing light may be fastened on the wall with or without mount.

- With a screwdriver, remove the transparent part of the flashing light by unscrewing the 2 screws that hold the upper part of the flashing light.
- Still with a screwdriver, remove the flashing light bracket by unscrewing the 2 screws inside the light.
- Fasten the flashing light bracket to the wall (ignore this step if you are fastening the light directly to the wall).
- Run the wires into the flashing light and connect them to the LED lightbulb (maintaining the “+” and “-” polarity).
- Screw the flashing light to its bracket and screw in the transparent part.

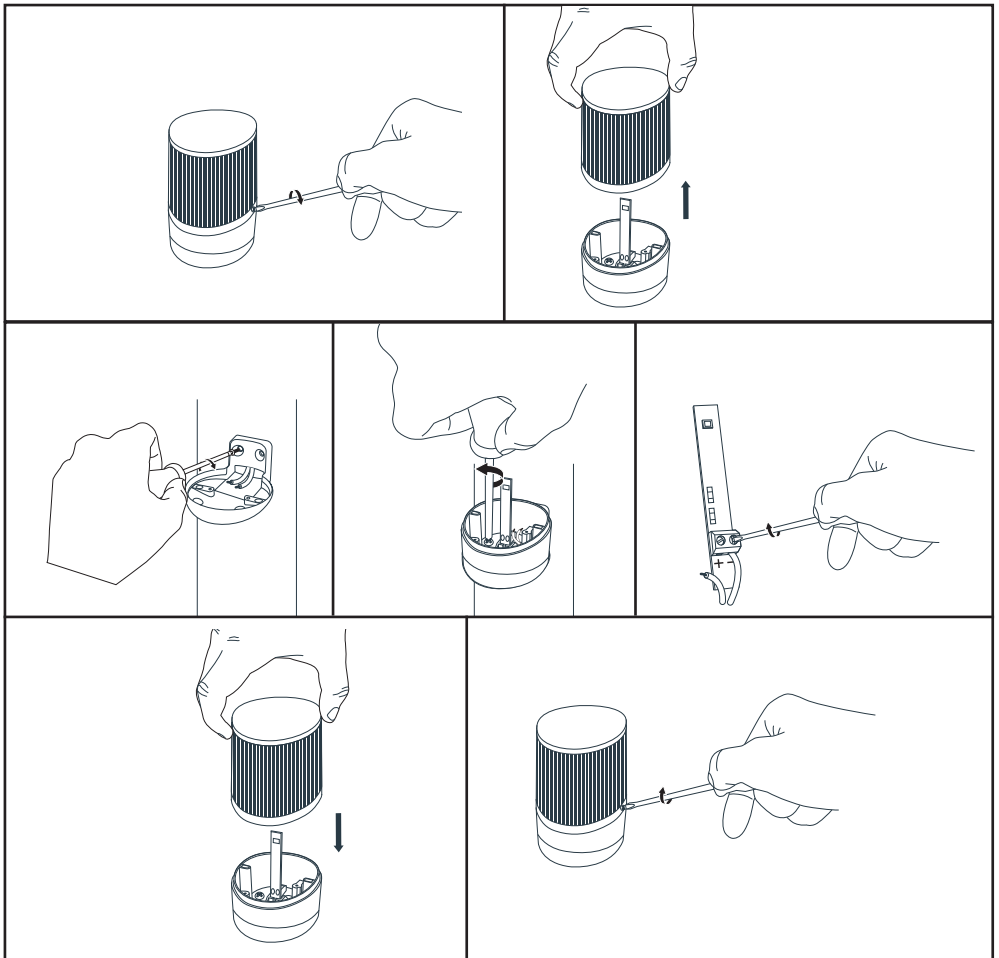

C - INSTALLATION

5. ATTACHING THE SET OF PHOTOCELLS

5.1 - Opening inwards

1 set of photocells

- Install the reception photocell (RX indicated on the back) on the motor post containing the electronic card. The surface of the posts must be perfectly flat in order to properly align the infrared beam of the photocells.
 - Place the photocells at exactly the same height from the ground; they must be perfectly aligned and parallel to each other.
- The distance between the outer side of the gate and the photocells must be between 10cm and 15cm.
- Mount the photocells on the posts.

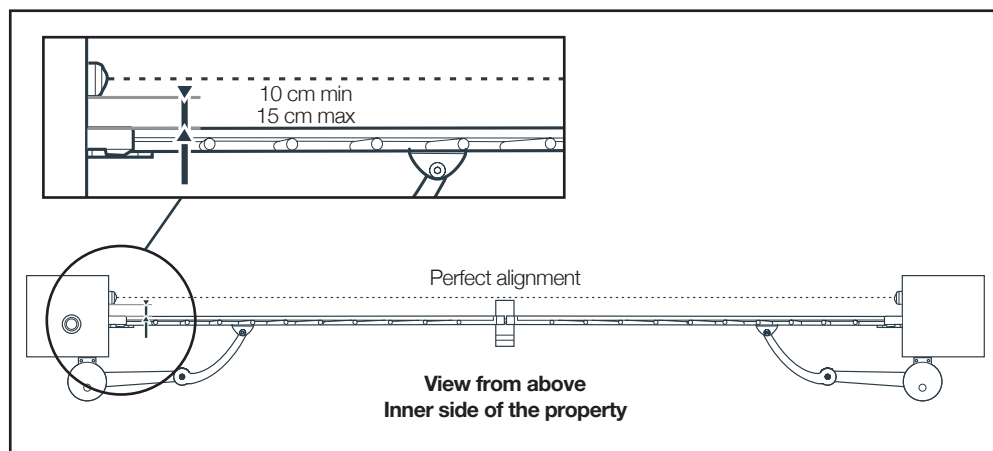
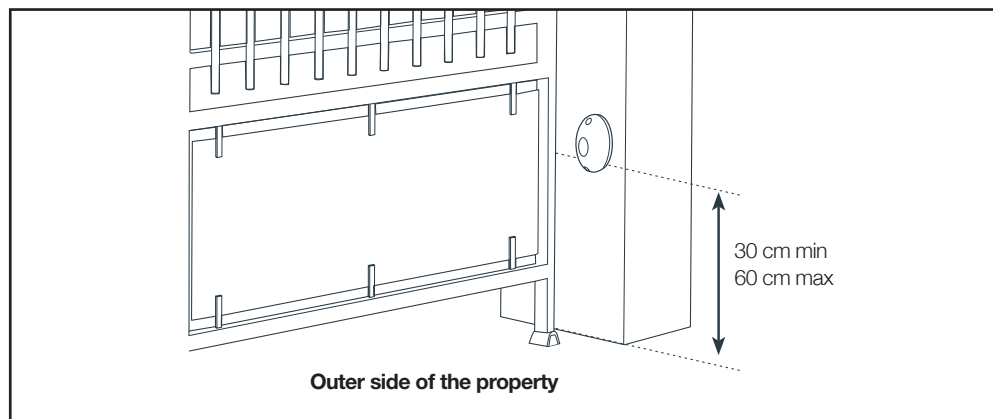

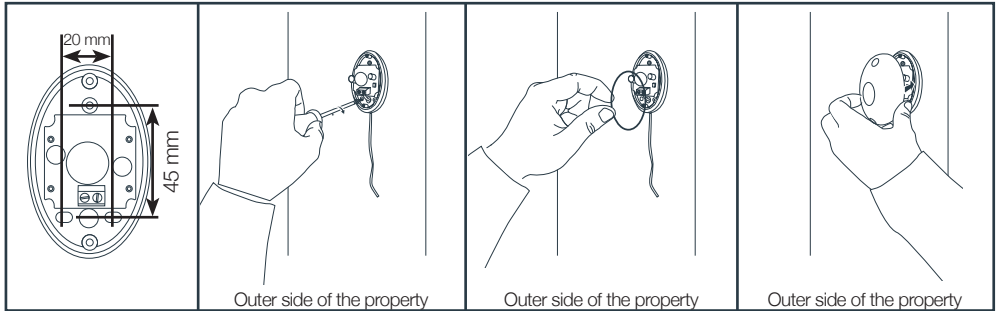

5.2 - Opening outwards

1 set of photocells

- Install the reception photocell (RX indicated on the back) on the motor post containing the electronic card. The surface of the posts must be perfectly flat in order to properly align the infrared beam of the photocells.
- Place the photocells at exactly the same height from the ground; they must be perfectly aligned and parallel to each other.
- Mount the photocells on the posts.

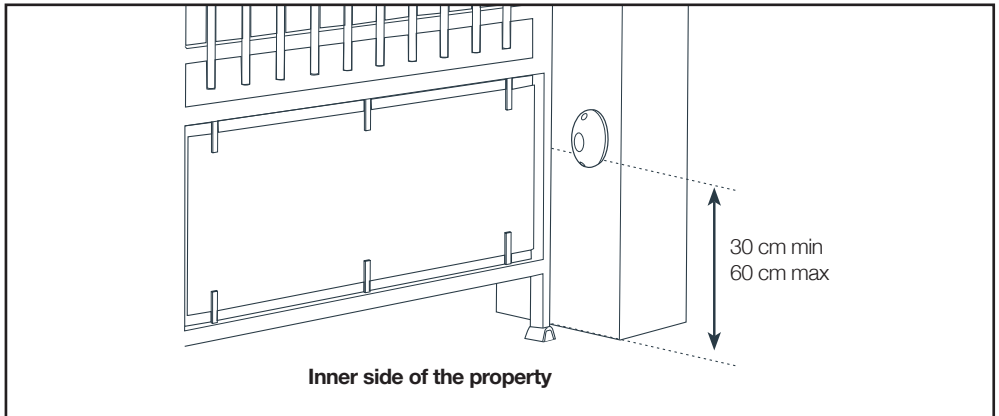

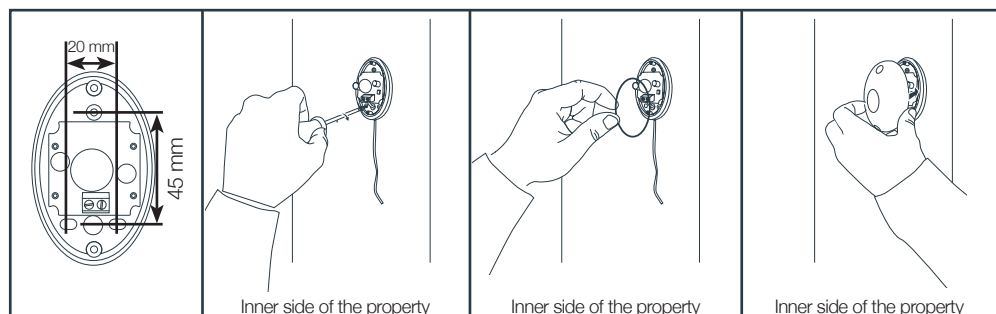
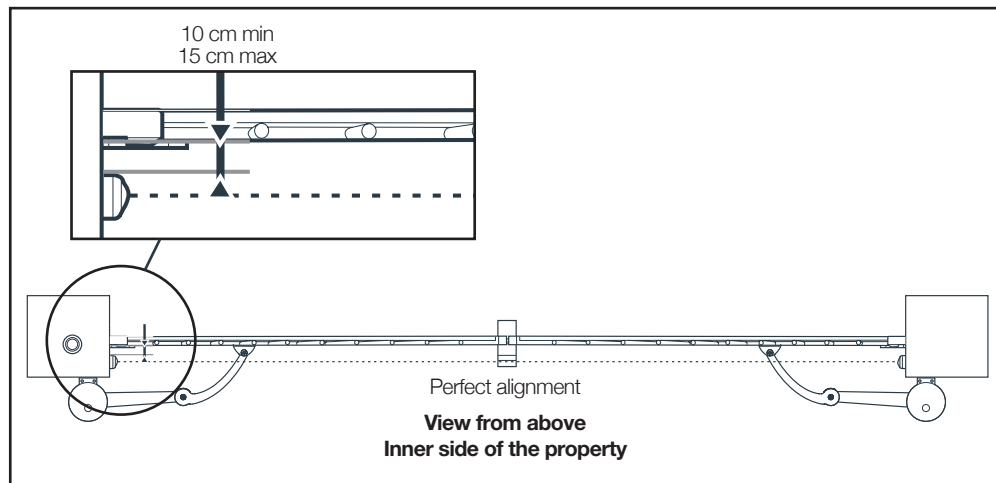

5.3 - 2nd set of photocells (optional)

For use when the gate is not visible. You must install a second set of photocells to prevent the gate from opening when an item (car, person, etc.) is behind the gate.

Installation:

- The photocells must be perfectly aligned and parallel to each other.
- The reception photocells (RX indicated on the back) must be installed facing the motor post where the electronic card is located (see drawing below).
- Additional photocells must be installed on the inner side for opening inward or on the outer side for opening outward. The distance between the main edges of the gate in an open position at 90° and the photocells must be between 10cm and 15cm maximum.
- The mounts used to secure the photocells must be correctly secured to the ground and precisely aligned.
- The photocells must be placed exactly at the same height from the ground, and the height must be between 30cm and 60cm.

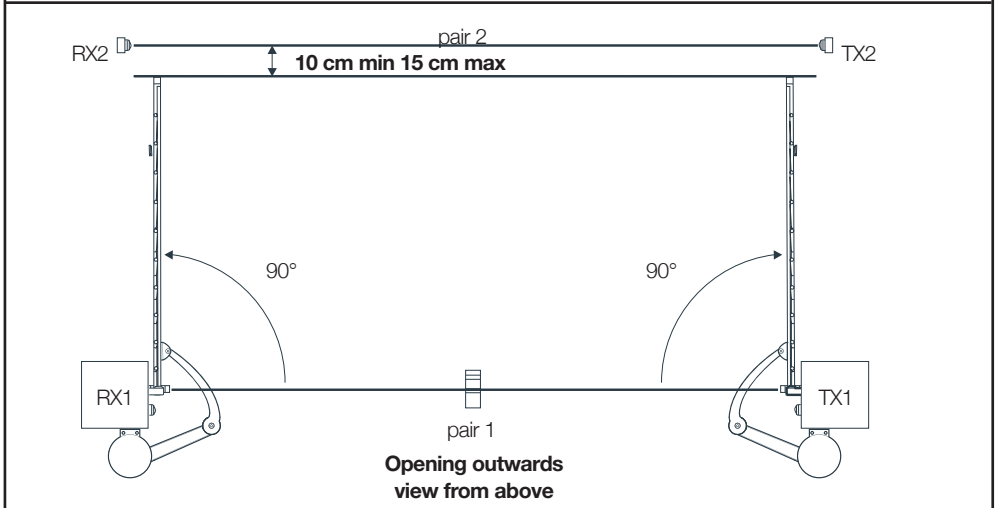
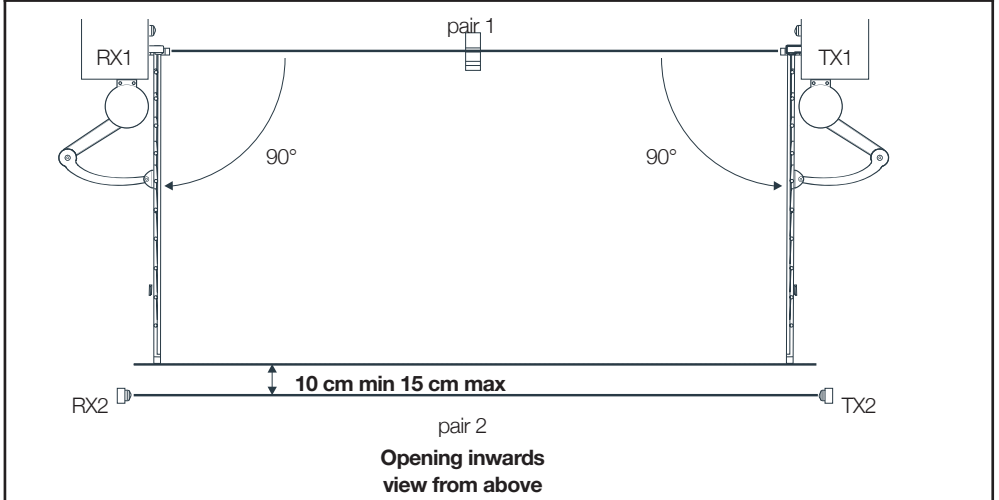
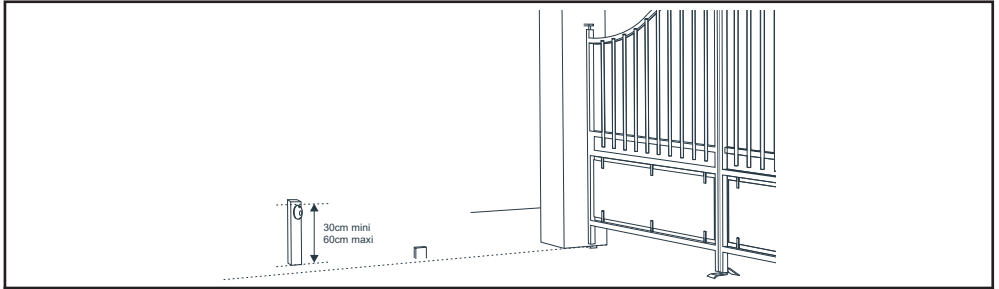

6. CONNECTIONS

- The cable run between must comply with applicable standards (NFC 15-100).
- Either the cable is 80cm deep with red warning mesh, or the cable is run through a sheath.

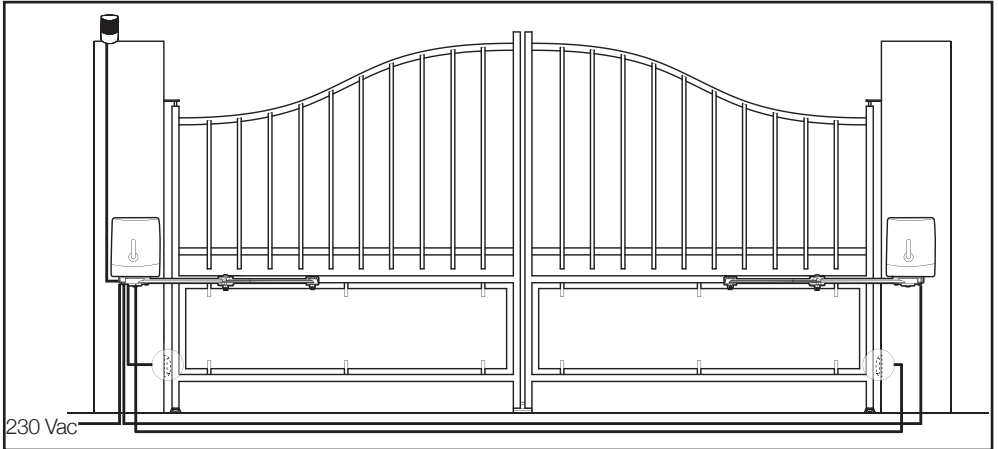

Safety instructions

- All electrical connections must be performed with the power switched off (safety switch in OFF position) and the battery disconnected.
- These connections must be made by a qualified electrician.

6.1 - Mains power supply

- Open the motor cover containing the control electronics to access the 230V power supply terminal block. Use the insulating screw joints provided to connect the 230V power supply.

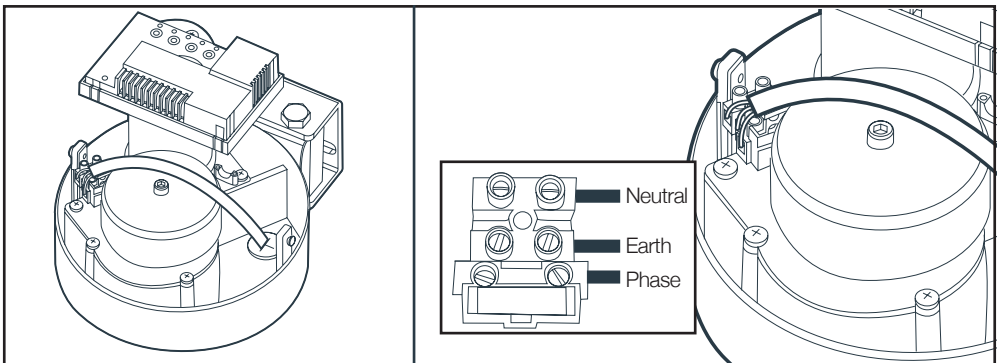

6.2 - Motors

For motor wiring without the electronic card, use a 2x1.5mm² cable and an insulating screw joint placed in the motor. Run the cable through the cable clamp and tighten

• Motor connection for opening towards the inside of the property

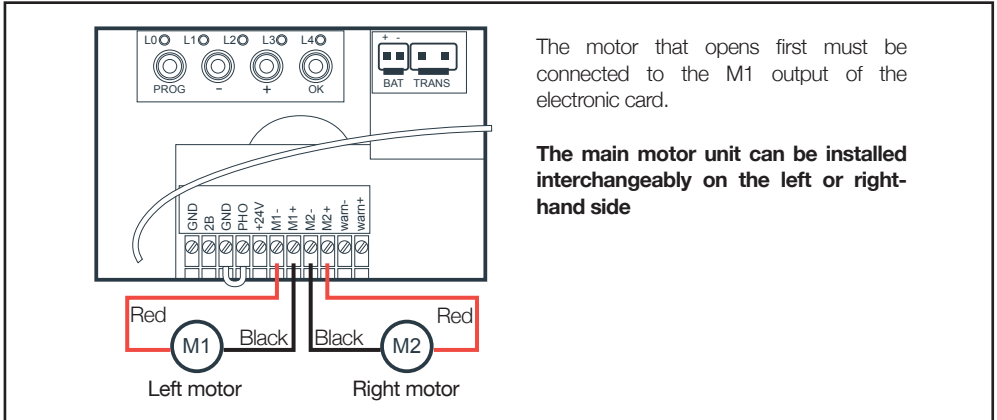

• Motor connection for opening towards the outside of the property

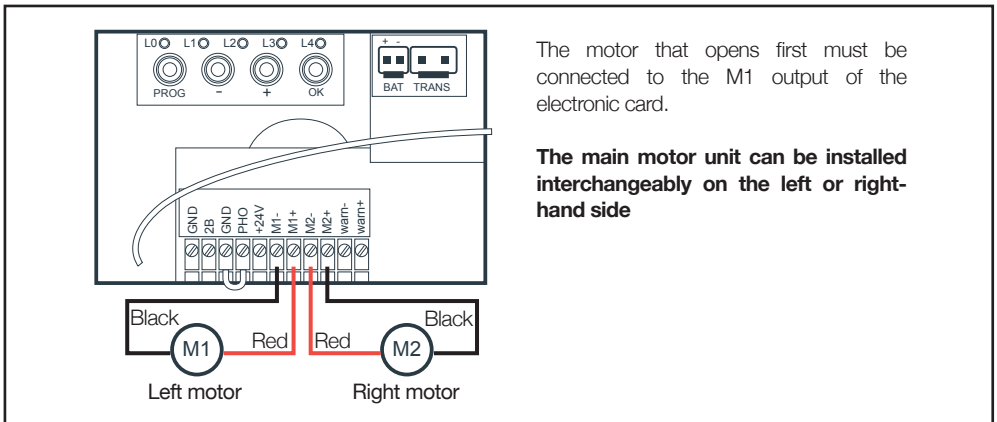

Manual card control

If you wish to check the operating direction of the motors, carry out the operation described below:

- Position the panels halfway open, engaged.
- Press the OK button on the card for 3 seconds, then release the button (L4 flashes).
- Press and hold the PROG button for a few seconds; the M1 motor should open while this button is pressed. If it closes, reverse the polarity.
- Press and hold the + button for a few seconds; the M2 motor should open when this button is pressed. If it closes, reverse the polarity.
- Exit manual control by pressing the PROG and - buttons once at the same time.

6.3 - Flashing light

- Connect the flashing light wires to the terminal block as shown in the diagram below and reconnect the terminal block.
- Use a 2x0.5 mm² section cable, at least.
- Maintain the connection polarity

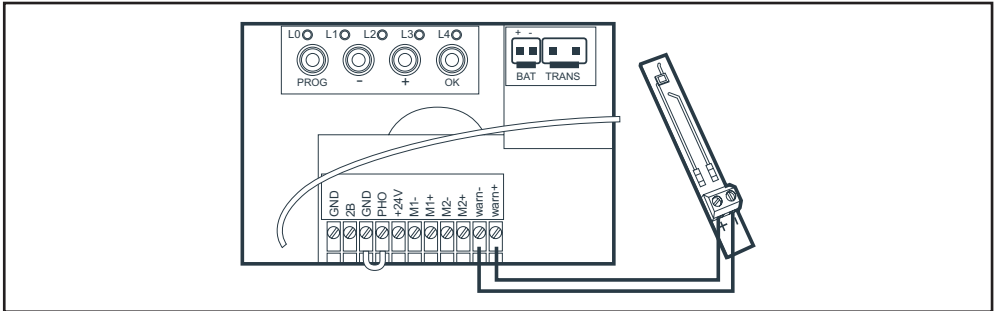

6.4 - Photocells

- **If there are no photocells, leave the connector between GND and PHO.**
- With one set of photocells, remove the connector between GND and PHO.

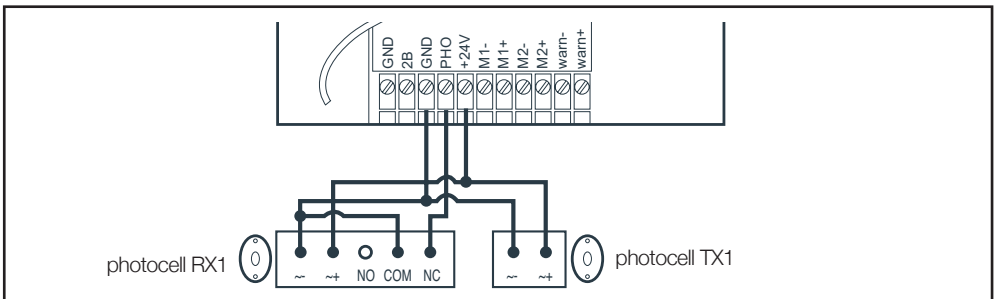

- With 2 sets of photocells, remove the connector between GND and PHO

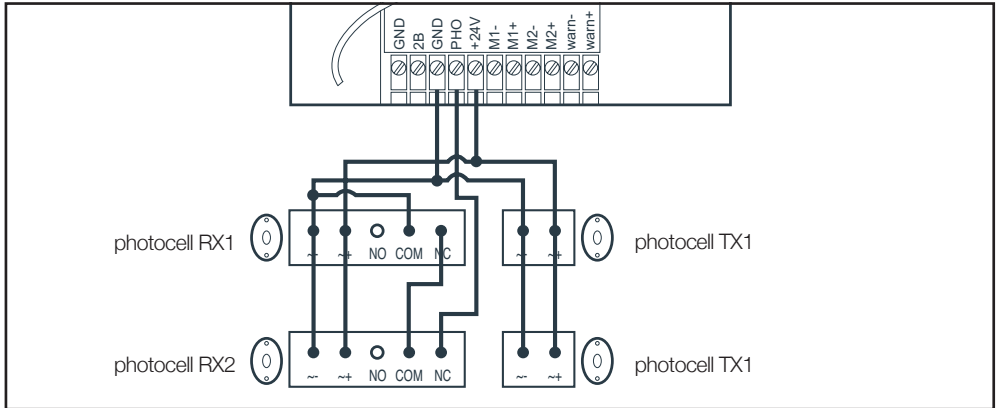

6.5 - Control parts (optional)

Note:

These control parts must be normally open dry contacts.

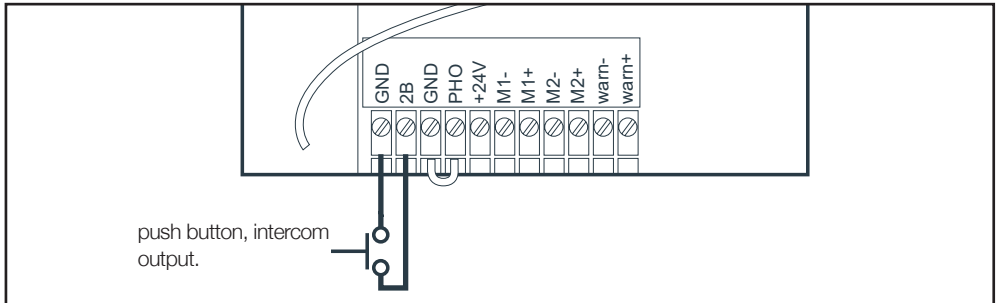

6.6 - Backup battery (optional)

It is possible to connect a backup battery to perform some manoeuvres in the event of power failure.

- Type of battery: NiMH
- Battery voltage: 24 V
- Configuration: 20xAAA / 800 mAh
- Use the connection cable supplied in the kit to connect the battery. Cut unnecessary terminals and use an insulating screw joint to connect the battery wires to this connecting cable.
- **Observe the connection polarity (red on + and black on -)**
- After connecting the battery, it will charge for up to 48H.

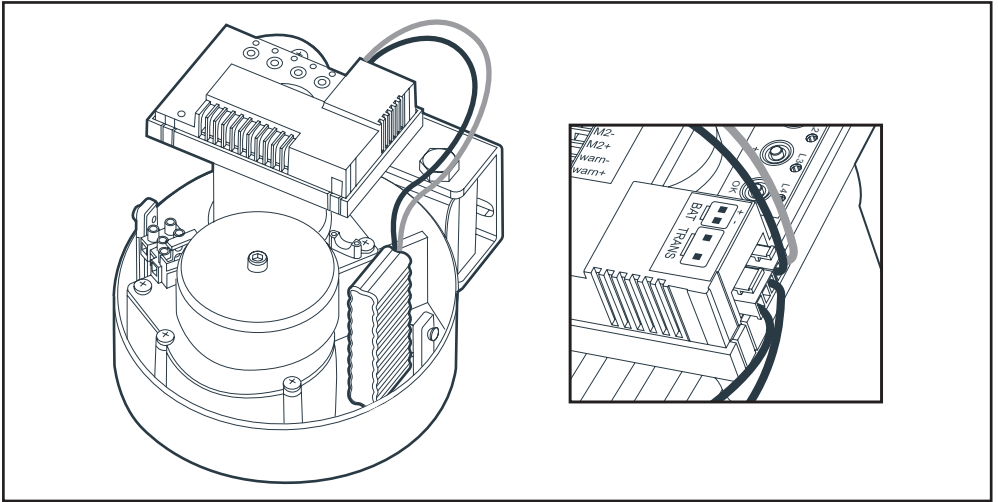

6.7 - Solar power kit (optional)

The 24 V solar power kit is plugged into the same connector as the backup battery. The solar power kit (which already has a battery) and a backup battery cannot be connected at the same time. For installation, refer to the solar power kit instructions.

When a solar power kit is connected, if you press the “OK” button on the electronic card, the number of red LEDs that light up indicates the battery charge level.

1. SETTINGS INTERFACE

Indicators

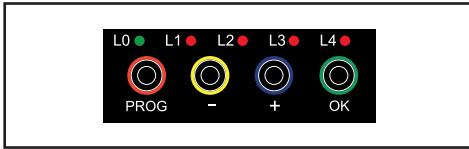

- **L0** = Green LED (switched off when the card is on standby)
- **L1 to L4** = Red LEDs to display information concerning settings, events (or errors) or battery status.

Buttons

PROG = Enter or exit settings menus.

"-" / "+" = Select a menu item, set a value, navigate the event log.

OK = Enter sub-menus, confirm a setting, view the battery voltage or history of events, enter manual control mode.

Important notes:

- Buttons can be pressed and released or pressed and held (for 3 seconds). When the instructions below indicate "**press the PROG button,**" the button must be pressed and released. When the instructions indicate "**press the PROG for 3s**" or "**PROG 3s,**" the button must be pressed and held.
- In the instructions below, the operations to be performed with the buttons will be described from **MENU 0**. It's the display menu that appears just after the power has been switched on for example, just after the gate has moved (before standby) or even when the card is on standby (in this case, the green LED L0 is switched off).
- To make sure you are at **MENU 0** of the display, press on **PROG** 2 or 3 times and only the green LED should be switched on.

When the user performs no action on a button for 15 seconds, the system automatically goes back to MENU 0.

2. BASIC SETTINGS (MENU 1)

2.1. Menu structure

After it is switched on, all LEDs will be turned off except the green LED

- If the green LED is off, the card is on standby mode. Press on **PROG** once (press and release) to activate the card. If no lights turn on, check that the power connections are correct.
- Lit up red LEDs are an error code. Check the error code table for the meaning. (If the card has already worked before, the last error code appears. This does not mean that there is a problem with the card).
- To clear the display of an error code, press and release **PROG** once.

Now to enter settings menu 1 (MENU 1), press PROG for 3 seconds and LED L1 will turn on.

- Menu item number 1 is selected. Press **+** or **-** to select another menu item and the red LED for that item will turn on accordingly.
- When a menu item is selected, press **OK** to view and change the related setting. See the chart below. The **+** and **-** buttons must then be used to change the setting value, and the **OK** button must be pressed to confirm it. If you do not wish to change a setting, you can exit by pressing **PROG** repeatedly (until only the green LED is lit).

The complete structure of the Level 1 menu is represented by the diagram below. The arrows indicated by one of the 4 buttons represent a press on the button (short or long if it indicates 3s).

Basic settings menu (MENU 1)

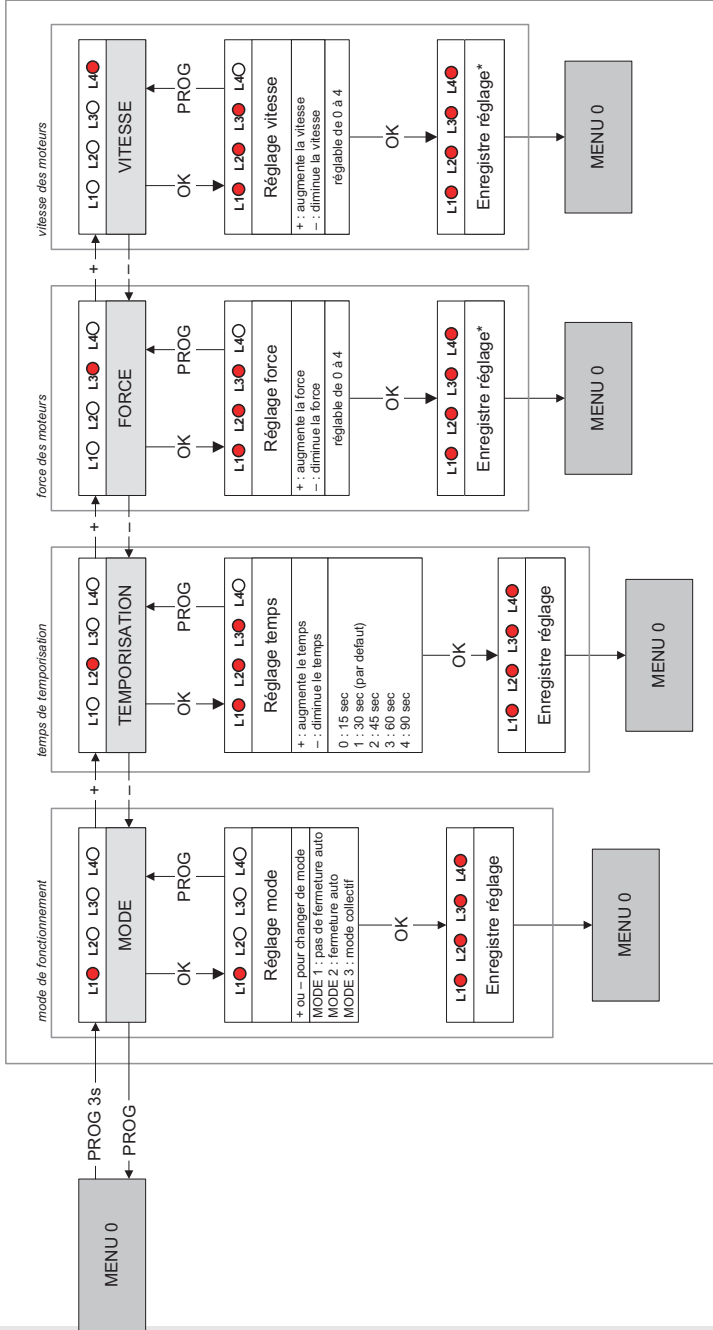

* cette modification nécessite de refaire un auto-apprentissage

2.2. Photocell alignment procedure (optional)

The electronic card of this motorised gate is on standby after 1 minute with no action.

On standby, the photocells no longer have power.

- To prolong the “activation” time, press and release one of the buttons.

When the photocells have power, a red indicator is lit inside each one.

When the photocells are not aligned, a second indicator light turns on in the RX photocells.

When the photocells are aligned, only one red indicator light turns on inside the RX photocell.

- Move your hand in front of it to hide the infrared beam. The second indicator light turns on and off. A relay click can be heard when the status changes.

2.3. Operating mode

This automatic gate opening mechanism has 3 operating modes.

Semi-automatic mode (mode 1) (default)

- Closed gate -> to open the gate, press and release the gate command.
- Open gate -> to close the gate, press and release the gate command.

While the gate is in motion, you can stop it by pressing the (gate or pedestrian) command.

By pressing on the gate command again, the gate swings in the opposite direction.

Automatic closing mode (mode 2)

- Closed gate: pressing and releasing the gate command once opens the gate, which remains open for a certain time (adjustable time, see “Time delay”), then closes automatically.
- During the time delay, you can cancel automatic closing by pressing the (gate or pedestrian) command. The gate stays open and you must press the gate command to close the gate.

While the gate is in motion, you can stop it by pressing the (gate or pedestrian) command.

Collective mode (mode 3)

This mode is used for a collective access gate.

- Closed gate: pressing and releasing the gate command once opens the gate, which remains

open for a certain time (adjustable time, see “Time delay”), then closes automatically.

Unlike the automatic closing mode:

- If you press a command during opening, it will not be acknowledged.
- If you press a command during the time delay, instead of cancelling automatic closing, the time delay starts again at 0.
- If you press a command during closure, the gate stops, opens again and starts the automatic closing time delay.
- **You can only control the complete gate. The pedestrian command does not work.**

To choose the operating mode, set a value from 1 to 3. Follow the procedure below

- Press **PROG** for 3 seconds. L0 will flash once and L1 will switch on.
- Press **OK** and the number of red LEDs that turn on will indicate the operating mode that has already been set (mode 1 by default).
- To change the operating mode, use the “-” and “+” buttons, then confirm with the **OK** button. All the LEDs turn on and off to confirm the operation.

N.B.: applicable regulations require the installation of photocells for security during automatic closing.

2.4. Time delay

The time delay is the time during which the gate remains open before closing automatically (if automatic closing is activated).

To adjust this value, follow the procedure below

- Press **PROG** for 3 seconds. L0 will flash once and L1 will switch on.
- Press “+” once. L2 will turn on instead of L1.
- Press **OK**, and the number of red LEDs that turn on will indicate the set value.
- Use the “-” and “+” buttons to change this value (see table below).
- Press **OK** to confirm this value. All the LEDs will turn on and off to confirm the operation.

This time is adjustable from 15 seconds to 90 seconds and is 15 seconds by default.

L1○ L2○ L3○ L4○	15 s
L1● L2○ L3○ L4○	30 s
L1● L2● L3○ L4○	45 s
L1● L2● L3● L4○	60 s
L1● L2● L3● L4●	90 s

2.5. Motor force

This system controls the force of the motors by detecting the maximum current they can absorb. As a result, if an obstacle pushes with enough force against a gate panel, the motor current exceeds the detected value and the gate stops. In most cases, it is not necessary to change this setting.

The force is adjustable from 0 to 4 and is set to 3 by default.

However, if the gate is solid and the force is insufficient, a gust of wind may cause one or more panels to stop.

- In this case, it is necessary to increase the level of force to 4.
- On the other hand, if the gate has a rather weak structure and a low wind load, it is recommended that the force be reduced.

Note

To meet the requirements of Standard 12453, it may be necessary to change the force of the motors.

To adjust the force, follow the procedure below

- Press **PROG** for 3 seconds. L0 will flash once and L1 will turn on.
- Press “+” twice and L3 will turn on instead of L1
- Press OK, and the number of LEDs that turn on will indicate the set force value.
- Use the “-” and “+” buttons to change the force and confirm with the **OK** button. All the LEDs will turn on and off to confirm the operation.

NOTE: if the force setting is changed, self-learning must be repeated.

2.6. Speed

You can adjust the speed by a value of 0 to 4. The default speed is 4.

If the gate is too fast, it may be necessary to reduce the speed.

To adjust the speed, follow the procedure below

- Press **PROG** for 3 seconds. L0 will flash once and L1 will turn on.
- Press “+” 3 times. L4 will turn on instead of L1.
- Press OK and the number of LEDs that turn on will indicate the set value.
- Use the “-” and “+” buttons to change this value.
- Press OK to confirm this value. All the LEDs will turn on and off to confirm the operation.

NOTE: if the speed setting is changed, self-learning must be repeated.

2.7. Self-learning

Role of self-learning

In order for the card to learn which motors are connected and the path of the door, self-learning must be launched.

In addition, if certain settings are changed (force, speed), self-learning must be repeated.

IMPORTANT

- The panels must have fixed stops at the end of the closing motion (central stop) and at the end of the opening motion (side stops), during self-learning, and they must not be moved or removed afterwards. If the stops are not firmly attached to the ground, this can lead to self-learning failure.
- The panels can be in any position (open, closed, ajar) before starting the self-learning procedure.

SAFETY

Make sure there is no one in the gate movement area during the entire start-up period and the entire test period.

D - BEGINNING OPERATION

Starting self-learning

- Check that you are not in a prog menu by pressing on prog 3 consecutive times
- Press and hold “+” for 3 seconds.

The self-learning procedure may be interrupted at any time by pressing OK.

Self-learning procedure

- The flashing light flashes.

• **Phase 0:** repositioning in central stop

Panel M2 closes up to the central stop.

Panel M1 closes up to the central stop.

• **Phase 1:** detection of side stops

Panel M1 opens up to the side stop.

Panel M2 opens up to the side stop.

• **Phase 2:** path detection

Panel M2 closes again up to the central stop

Panel M1 closes again up to the central stop.

• **Phase 3:** learning opening and closing

Panel M1 starts to open, gradually accelerating.

Panel M2 starts to open, gradually accelerating, 2.5 seconds (or more depending on the setting, see MENU 3) after M1.

The panels reach their opening stops.

Panel M2 starts to close, gradually accelerating.

Panel M1 starts to close, gradually accelerating.

The panels reach the central stop (with a difference of 2.5 seconds or more depending on the setting, see MENU 3)

Error during self-learning

If self-learning does not work as described above and stops earlier than expected (the motors and the flashing light stop), some of the red LEDs will be on or flashing, and others will be off. The configuration of the red LEDs that are on provides an error code allowing the installer to determine the source of the incident that has occurred.

Below is a table indicating the self-learning error codes:

□: LED off

■: LED on

⏏: Flashing LED light

Make sure not to confuse the self-learning error codes with error codes of events that may occur during normal operation and which are indicated in the same way by a combination of red LEDs that are on / off / flashing.

(See page 47)

L1	L2	L3	L4	Description
□	□	□	■	In phase 0, panel M1 did not arrive at a stop after closing for 60s, disengagement or cable section too weak?
□	■	□	□	In phase 0, panel M2 did not arrive at a stop after closing for 60s, disengagement or cable section too weak?
□	■	■	■	In phase 0, motor M1 was not detected (not / incorrectly connected?).
■	□	□	□	In phase 0, motor M2 was not detected (not / incorrectly connected?).
■	□	□	■	In phase 1, motor M1 reached the stop after opening for less than 3s: reduce the speed.
■	□	■	□	In phase 1, motor M2 reached the stop after opening for less than 3s: reduce the speed.
■	□	■	■	In phase 1, panel M1 did not reach a stop after opening for 60s or cable section too weak?

■	■	□	□	In phase 1, panel M2 did not reach a stop after opening for 60s or cable section too weak?
■	■	□	■	In phase 1, motor M1 was not detected (contact failure, electronic card problem?). Review motor connections.
■	■	■	□	In phase 1, motor M2 was not detected (contact failure, electronic card problem?). Review motor connections.
□	■	■	■	In phase 1 (opening), M1 is not recognised. Note 1.
■	□	□	□	In phase 1 (opening), M2 is not recognised. Note 1.
■	□	□	■	In phase 2 (closing), M1 is not recognised. Note 2.
■	□	■	□	In phase 2 (closing), M2 is not recognised. Note 2.
■	□	■	■	Self-learning was interrupted by the user.

Note 1: many possible causes:

- The motor was not recognised as compatible with the electronic card.
 - There is a fault in the motor.
 - The section of the motor cable is too weak
 - A gust of wind prevented the system from recognising the motor.
- Repeat the self-learning procedure and assist the panel opening process during the start of phase 2 if wind speed remains high.

Note 2: many possible causes:

- The motor was not recognised as compatible with the electronic card.
 - There is a fault in the motor.
 - The section of the motor cable is too weak.
- Try again by repeating the self-learning process.

2.8. Programming remote controls

It is possible to open both panels (gate) or a single panel (pedestrian) by remote control.

On a remote control, it is possible to decide which button will be used as the gate command and which button will be used as the pedestrian command.

2.8.1. Programming with the card

Note:

It is possible to programme a remote control once, then use the “copy” function that allows you to programme additional remote controls without using the electronic card, via a remote control that has already been programmed. (This is useful when additional remote controls are available for programming without having to open the electronic control box).

Programming a button for the GATE OPENING command

- Press “-” for 3 seconds and L1 will switch on.
- Press **OK** and L1 and L4 will turn on alternately.
- Within the next 10 seconds, press the remote control button for memorisation.
 - If the red LEDs all turn on for 1 second, this means that memorisation is successful.
 - If the red LEDs all flash 3 times, this means that the system has waited for more than 10 seconds without receiving valid information. Restart the programming.

Programming a button for the Pedestrian OPENING command

- Press “-” for 3 seconds and L1 will switch on.
- Press “+” and L1 will switch off and L2 will switch on.
- Press **OK** and L1 and L4 will turn on alternately.
- Within the next 10 seconds, press the remote control button for memorisation.
 - If the red LEDs all turn on for 1 second, this means that memorisation is successful.
 - If the red LEDs all flash 3 times, this means that the system has waited for more than 10 seconds without receiving valid information. Restart the programming.

2.8.2. Copy programming

From a remote control that has already been memorised, you can memorise other remote controls ("copy" function).

For each new remote control to be memorised, follow the procedure below

• **Stand near the motor.**

- Press simultaneously on both buttons at the bottom of the remote control already in the memory until the flashing light switches on (around 6 seconds).
- Press any button on the new remote control. The flashing light will flash 3 times and then turn off.

The new remote control is now memorised (the buttons will have the same function as the original remote control).

2.8.3. Deleting all remote controls

To deprogram all the remote control buttons learnt, follow the procedure below

- Press "-" for 3 seconds and L1 will switch on.
- Press "+" twice and L1 will turn off and L3 will turn on.
- Press **OK**. The 4 red LEDs will turn on.
- Press **OK** for 3 seconds. All the LEDs will turn off and turn on to confirm the operation.

3. ADVANCED SETTINGS

Certain adjustments may be necessary in the event of a problem or for specific use of the electronic card. There are two additional menus with basic settings.

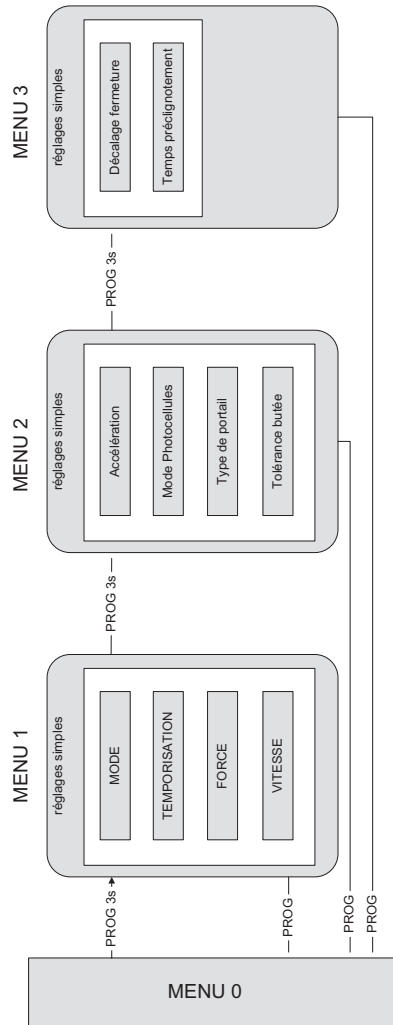

D - BEGINNING OPERATION

3.1. Access to advanced settings (MENU 2 and 3)

To access menus 2 and 3, follow the procedure below

- Press **PROG** for 3 seconds. L0 will flash once, L1 will turn on and you will be in **menu 1 (basic settings)**.
- Press **PROG** again for 3 seconds. L0 will flash twice, L1 will turn on and you will be in **menu 2 (advanced settings)**.
- Press **PROG** again for 3 seconds. L0 will flash twice, L1 will turn on and you will be in **menu 3 (advanced settings)**.

To adjust the acceleration, follow the procedure below

- Press **PROG** for 3 seconds. L0 will flash once and L1 will turn on.
- Press **PROG**, for 3 seconds. L0 will flash twice.
- Press **OK** and the number of LEDs that turn on will indicate the set value.
- Use the “-” and “+” buttons to change this value.
- Press **OK** to confirm this value. All the LEDs will turn on and off to confirm the operation.

PLEASE NOTE: If the acceleration setting is changed, self-learning must be repeated.

3.2. Advanced settings menu (MENU 2)

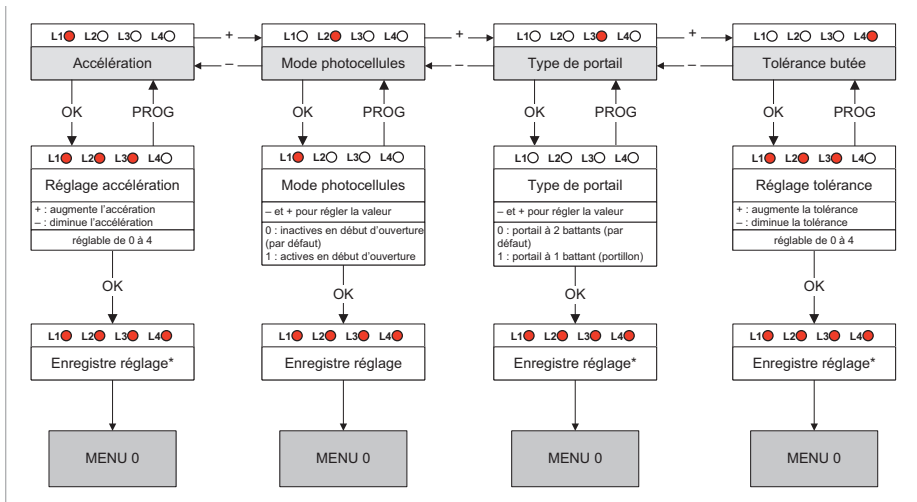

This change requires a new self-learning procedure.

3.2.1. Acceleration

The acceleration at the start of the panel opening process can be adjusted from a level of 0 to 4. The higher this value, the more time the gate will take to open. The default level is 3, at which the gate takes about 4 seconds to open. It may be useful to reduce the acceleration for a softer start.

D - BEGINNING OPERATION

3.2.2. Photocell mode

The photocells are active when the panels close because they are placed between the posts (pair 1) to secure the passage between panels.

The installation of a second set of photocells is useful to completely protect the gate movement area during closing and opening:

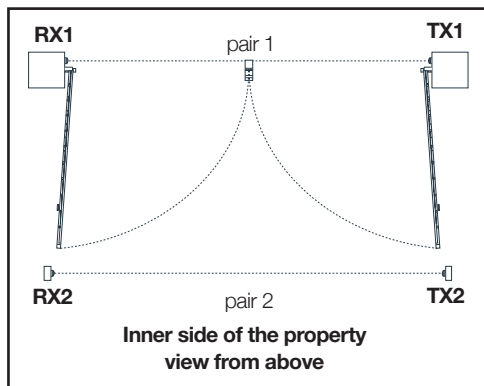

In that case, the system must verify that its infrared beam is not obstructed before starting to open the panels. But by default, photocells are only tested during closure.

To activate or deactivate photocells at the beginning of the opening process, follow the procedure below

- Press **PROG** for 3 seconds. L0 will flash once and L1 will switch on.
- Press **PROG** for 3 seconds. L0 will flash twice.
- Press **“+”** once. L2 will turn on instead of L1.
- Press **OK**.
- If L1 is off, the photocells are inactive at the beginning of the opening process. Press **“+”** to activate them, then **OK** to confirm. All LEDs will turn on and off to confirm the operation.
- If L1 is on, the photocells are active at the beginning of the opening process. Press **“-”** to deactivate them, then **OK** to confirm. All LEDs will turn on and off to confirm the operation.

3.2.3. Type of gate

To operate the electronic card on a single-panel gate, this setting must be changed. By default, this value is set to 0 (two-panel gate mode).

In addition, the motor output that remains active in side gate mode is M1 (not to be confused with the pedestrian passage function).

To activate or deactivate this function, follow the procedure below

- Press **PROG** for 3 seconds. L0 will flash once and L1 will turn on.
- Press **PROG** for 3 seconds. L0 will flash twice.
- Press **“+”** twice and L3 will switch on instead of L1.
- Press **OK**.
- If L1 is off, gate mode is activated. Press **“+”** to activate side gate mode, then **OK** to confirm. All LEDs will turn on and off to confirm the operation.
- If L1 is on, side gate mode is activated. Press **“-”** to activate gate mode, then **OK** to confirm. All LEDs will turn on and off to confirm the operation.

Self-learning is required if this setting is changed.

3.2.4. Stop tolerance

During self-learning, the system learns the path of each panel to determine when a panel stops if it has reached a stop or an obstacle. In fact, during a movement, if more than a certain percentage of the path remains to be completed by the panel but it comes under strain, the system considers it to be pushing against an obstacle. If the panel comes under strain when less than such percentage remains to be completed, the system considers that the panel has reached its stop. By default, this percentage is 3%.

However, the accuracy of the system depends on many parameters, such as temperature, motor quality, the type of motor cables and the flexibility and weight of the gate. Depending on these parameters, the path measuring system may not be accurate enough to operate with this default tolerance. In this case, the system can trigger obstacle detection when the panels reach their normal stop. If this occurs (and after confirming that the opening and closing stops are stable), the obstacle detection tolerance must be increased.

D - BEGINNING OPERATION

To adjust this tolerance level, follow the procedure below

- Press **PROG** for 3 seconds. L0 will flash once and L1 will switch on.
- Press **PROG** for 3 seconds. L0 will flash twice.
- Press **+** three times. L3 will turn on instead of L1.
- Press **OK**. The number of LEDs that turn on will indicate the set value.
- Use the **–** and **+** buttons to change this value. The higher the value, the higher the tolerance level (“lower risk of obstacle detection at the stop”).
- Press **OK** to confirm this value. All the LEDs will turn on and off to confirm the operation.

Self-learning is required if this setting is changed.

3.3 - Advanced settings menu (MENU 3)

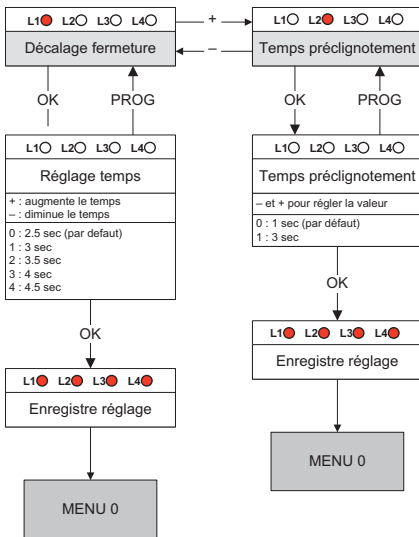

3.3.1. Panel movement time difference

In general, on closing, one gate panel closes over the other. This panel is controlled by the motor connected to output M1 of the electronic card. To ensure that the panels close in the correct order, the system arranges for the panel of motor M2 to come to a stop 2.5 seconds before the panel of motor M1. If the gate is solid and exposed to the wind, panel M2 may be stopped by the wind and panel M1 may be helped by the wind on closing. In this case, panel M1 may catch up to panel M2 and the panels may close in the wrong order.

If this occurs, the time interval between the panel movements during closure may be increased.

To adjust this time interval, follow the procedure below

- Press **PROG** for 3 seconds. L0 will flash once and L1 will switch on.
- Press **PROG** for 3 seconds. L0 will flash twice.
- Press **PROG** for 3 seconds. L0 will flash 3 times.
- Press **OK**. The number of LEDs that turn on will indicate the set value.
- Use the **–** and **+** buttons to change this value (see table below).
- Press **OK** to confirm this value. All the LEDs will turn on and off to confirm the operation.

L1○ L2○ L3○ L4○	2.5 s (par défaut)
L1● L2○ L3○ L4○	3 s
L1● L2● L3○ L4○	3.5 s
L1● L2● L3● L4○	4 s
L1● L2● L3● L4●	4.5 s

Note: During opening, there is also a time interval between the panel movements, but this time interval is fixed and is equal to 2.5 seconds.

3.3.2 - Pre-flashing time

The flashing light is an important safety component. It starts when a command to set the gate in motion is received by the electronic card. The gate is set in motion around one second after a command is received.

In certain use cases, it is better that the time between receiving a motion command and the start of the manoeuvre is longer. It is possible to increase this time to 3 seconds.

To set the pre-flashing time, follow the procedure below

- Press **PROG** for 3 seconds. L0 will flash once and L1 will turn on.
- Press **PROG** for 3 seconds. L0 will flash twice.
- Press **PROG** for 3 seconds. L0 will flash 3 times.
- Press **“+”** once. L2 will turn on instead of L1.
- Press **OK**.
- If L1 is off, the time is 1 second. Press **“+”** to increase it to 3 seconds, then **OK** to confirm. All LEDs will turn on and off to confirm the operation.
- If L1 is on, the time is 3 seconds. Press **“-”** to reduce it to 1 second, then **OK** to confirm. All LEDs will turn on and off to confirm the operation.

1. WARNINGS

An automatic gate opening mechanism is a product that can cause injury to people and animals and damage to property. Our motorised gate as well as its installation and user guides were designed to remove all hazardous situations.

Avidsen cannot be held liable for any installation or use that does not comply with the instructions and causes damage. It is essential to read the instructions carefully before using your motorised gate and to keep these instructions for any later use.

General Safety Obligations

- This device may be used by children 8 years of age or older and by persons with reduced physical, sensory or mental abilities or a lack of experience or knowledge, if they are properly supervised or if instructions on the safe use of the device have been provided to them and the possible hazards have been understood. Children must not play with the device. Cleaning and maintenance by the user should not be performed by unattended children.
- All potential users must be instructed in the use of the motorised gate by reading this user guide.
- No untrained person (child) must set the gate in motion using the fixed (key selector) or portable (remote control) devices.
- Prevent children from playing near or with the motorised gate.
- Do not deliberately stop the moving gate, except of course with a control device or for an emergency stop.
- Prevent any natural obstacles (branches, stones, high grass, etc.) from hindering the gate's movement.
- Do not manually operate the gate when the motors are not disassembled.
- Before setting the gate into motion, ensure that there is no person in the area in which the gate moves (children, vehicles, etc.).
- In the event of a malfunction, disassemble the motors to allow passage and contact your installer. Do not attempt to fix the product yourself.
- Do not alter or add components to the system without discussing it with the installer.

2. OPENING/CLOSING

The gate can be controlled from a programmed remote control, a programmed wireless code keypad or a wired control device.

3. TYPE OF COMMAND

There are two types of command to manoeuvre the gate:

• Gate control



• Pedestrian control



- The gate control controls the opening, stopping and closing of both panels.
- The pedestrian control is used to control the opening, stopping and closing of the panel driven by motor M1.
- The pedestrian control can also be used to stop the two panels.
- The pedestrian control cannot be used to close M1 if M2 is not fully closed.
- Automatic closing and photocells are not active for pedestrian control.

4. OPERATING MODES

The operating mode is set by following the instructions in the "OPERATING MODE" section.

4.1. "Semi-automatic closing" mode

Description of operation from the closed gate position:

To open the gate:

- Activate the complete (or partial) opening command.
- The flashing light will flash (1 flash per second).

- 1 second later, panel M1 starts opening.
- 2.5 seconds later, panel M2 starts opening.
- Both panels open up to their opening stop.
- When both panels have reached their opening stop, the flashing light will stop flashing and the manoeuvre will be complete.

To close the gate:

- Activate the complete or partial opening command.
- The flashing light will flash (1 flash per second).
- 1 second later, panel M2 starts closing.
- A few seconds later, panel M1 starts closing.
- Panel M2 reaches its closing stop.
- Some time later (2.5 seconds by default, but this time can be adjusted), panel M1 reaches its closing stop.
- The flashing light will stop flashing and the manoeuvre will be complete.

At any time, you can stop the gate's movement by activating a command (total or partial). If you activate the gate control again, the gate will start in the opposite direction.

4.2. "Automatic closing" mode

Description of operation from the closed gate position; the photocells must be operational:

- Activate the complete opening command.
- The flashing light will flash (1 flash per second).
- 1 second later, panel M1 starts opening.
- 2.5 seconds later, panel M2 starts opening.
- Both panels open up to their opening stop.
- When the two panels have reached their opening stop, the flashing light begins to flash differently (1 flash every 1.25 seconds) and the time delay before closing starts.
- When the time delay is over, the flashing light will resume its normal pace (1 flash per second).
- 1 second later, panel M2 starts closing.
- A few seconds later, panel M1 starts closing.
- Panel M2 reaches its closing stop.
- Some time later (2.5 seconds by default, but this time can be adjusted), panel M1 reaches its closing stop.
- The flashing light will stop flashing and the manoeuvre will be complete.

At any time, you can stop the gate's movement by activating a command (total or partial). If you activate the gate control again, the gate will start in the opposite direction. If you activate a command during the time delay, it will be stopped and automatic closing will be cancelled.

4.3. "Collective" mode

Operation is identical to "automatic closing" mode, except:

The photocells must be operational.

- You cannot stop the gate from opening, either with the complete or partial opening command.
- If you activate the complete opening command during the time delay, it is reloaded with the initial time to extend the time before automatic closing.
- If you activate the complete opening command during closure, the gate will stop and open again and the time delay before automatic closing will start.
- The partial opening command is inoperative.

5. PHOTOCELLS

- During closure, if an object or a person obstructs the infrared beam between the two photocells, the gate will stop and start opening again. If automatic closing is activated, the time delay will start. If, at the end of the time delay, the photocell beam is cut, the gate will wait for the beam to be cleared before closing again. If, after 3 minutes, the beam has still not been cleared, automatic closing will be cancelled and the system will go on standby.
- Photocells can also be active at the beginning of the opening process (this is useful if a second set of photocells is installed - see "Advanced Settings (Menu 2)").
- If this is not the case and the beam is obstructed when the gate should start to open, the flashing light will emit double flashes for 30 seconds unless a command is activated. For the gate to be able to open, the beam must be unobstructed and a command must be activated.

5.1. Obstacle detection

During their movement, the panels may encounter an obstacle.

- For safety purposes, if the motors are under too much strain (the force is adjustable; see “Motor Force” in the settings), the gate stops and releases the pressure and the flashing light emits double flashes for 30 seconds unless a command is activated.
- On activating a command (the same one that was used to start the movement), the gate starts to move in the opposite direction.
- If an obstacle is detected during closure and the operating mode is “automatic closing” or “collective”, the gate will open again and the time delay will restart.
- If the gate has a large area of wind resistance (solid gate), this can trigger obstacle detection in windy weather. In this case, increasing the motor force is recommended.

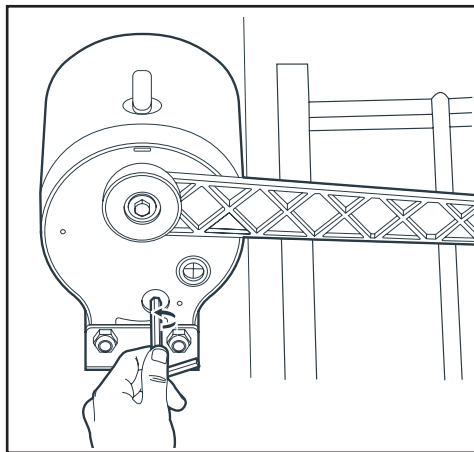

6. MANUAL MOVEMENT

To manually operate the gate, simply disengage each motor using the key provided (part 21). Insert the key into the override system under the engine and turn counterclockwise (view from below). Refer to the instructions on the motor next to the override system.

To engage, perform the opposite operation (turn clockwise), then move each panel until it locks.

Warning:

When the motors are disengaged, the gate may be set in motion by the wind or an external push. It is therefore important to be careful or block the gate to avoid any risk of injury.

1. MAINTENANCE WORK

Maintenance work must be carried out by the installer or a qualified individual to guarantee the installation's operation and safety.

The number of maintenance and upkeep operations must be proportional to the frequency the motorised gate is used.

For use of about 10 cycles per day, it is necessary to provide:

- maintenance of the mechanical parts every 12 months: tightening screws, lubrication, checking the hinges, stops and gate balance, etc.
- maintenance of the electronic parts every 6 months: engine operation, photocells, control devices, etc.

Please note: The warranty may be voided if the motor drive and gate are not checked regularly.





Important: All the installation or maintenance operations must be performed with the motor drive disconnected from electrical power supply.

If the disconnection device is not visible where the motor drive is located, before starting work, you must attach a sign to the disconnection device. The first check must be carried out 1 month after installation, to check that all the instructions have been followed.

Points to check:

- The water inputs (the product is intended for outdoor use, however, incorrect positioning of the lid, the holes made to run the cable, or an incorrectly positioned grommet... can damage the product). Any trace of infiltration must be eliminated (if silicone is used, do not use an acetic acid-based silicone (smells like vinegar)).
- Traces of external items (Insects can sometimes find refuge in the fixed parts. Their presence must be eliminated and the possible entrances closed off).
- The 1st month of use already gives a good idea of the motorised gate's operation.

The following checks must be performed each time the season changes:

	printemps 	été 	automne 	hiver 
lubrifier les gonds*...	...qui ont été lavés par les pluies	...qui sont encombrés par les poussières	...qui ont été lavés par les pluies	...qui subissent le gel ou la neige
lubrifier toutes les pièces en mouvement sur l'automatisme	x	x	x	x
éliminer tous les obstacles susceptibles de bloquer le mouvement du portail	herbes cailloux etc	herbes cailloux etc	feuilles mortes, herbes, cailloux etc	cailloux, neige etc
vérifier les sécurités	détection ampère métrique, arrêt d'urgence, photocellules			
vérifier que les zones dangereuses (cisaillement, écrasement...) soient toujours protégées	x	x	x	x
vérifier les avertisseurs (clignotant)	x	x	x	x
vérifier les réglages (force, temps de réaction, sensibilité)**	x	x	x	x
contrôler l'état de la carte électronique (élimination des poussières, insectes etc)	x	x	x	x
vérifier les commandes (interphones, clavier, pousoir)	x	x	x	x
vérifier les piles des télécommandes	x	x	x	x
vérifier le support moteur (déformation etc) et les fixations	x	x	x	x

* do not use fat, which tends to attract dust or dirt ** note that one adjustment made in summer may need to be changed according to the seasons (more wind in autumn, frost in winter, etc.) *** vibrations due to opening and closing may move the racks. Check the 1mm distance between the teeth and the motor gear.

2. OPERATING INDICATORS

This system has two operating indicators: the battery charge level (optional) and the event log.

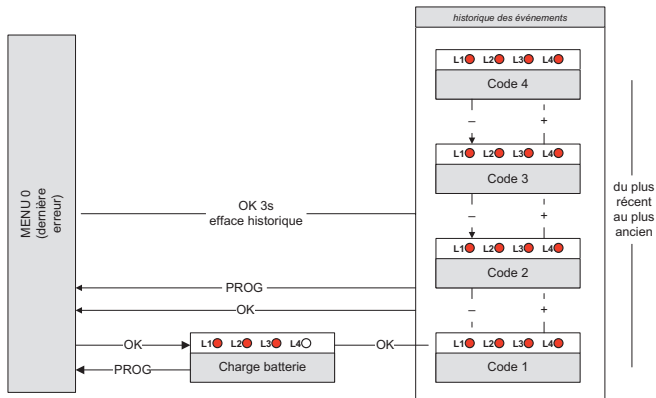

2.1. History of events and error codes

- During operation, events may occur that may be malfunctions of the motor drive or consequences of user actions.
- Each event has a different code.
- This code is displayed by a combination of red LEDs that are on, off or flashing on the **MENU 0** display.
- When **OK** or **PROG** are pressed, this code is deleted. However, the last 4 codes generated are memorised and can be viewed in a log.
- To access them, press **OK** twice, then use the “+” and “-” buttons to scroll through the memorised codes.

To diagnose any problems, here is the list of codes and their meaning:

- : LED off
- : LED on
- : Flashing LED light

There are two types of code: Error (E) or Information (I). N.B. an error requires action from the installer to correct the motor drive problem.

L1	L2	L3	L4	MEANING	TYPE
<input type="checkbox"/>	<input type="checkbox"/>	<input type="checkbox"/>	<input checked="" type="checkbox"/>	An obstacle has been detected in M1 when closing.	I
<input type="checkbox"/>	<input type="checkbox"/>	<input checked="" type="checkbox"/>	<input type="checkbox"/>	An obstacle has been detected in M2 when closing.	I
<input type="checkbox"/>	<input checked="" type="checkbox"/>	<input checked="" type="checkbox"/>	<input checked="" type="checkbox"/>	The photocell beam has been obstructed.	I
<input checked="" type="checkbox"/>	<input checked="" type="checkbox"/>	<input checked="" type="checkbox"/>	<input type="checkbox"/>	An obstacle has been detected in M1 when opening.	I
<input checked="" type="checkbox"/>	<input checked="" type="checkbox"/>	<input checked="" type="checkbox"/>	<input checked="" type="checkbox"/>	An obstacle has been detected in M2 when opening.	I

<input type="checkbox"/>	<input type="checkbox"/>	<input type="checkbox"/>	<input checked="" type="checkbox"/>	Motor M1 is not connected or incorrectly connected (contact failure). Check connections.	E
<input type="checkbox"/>	<input type="checkbox"/>	<input checked="" type="checkbox"/>	<input type="checkbox"/>	Motor M2 is not connected or incorrectly connected (contact failure). Check connections.	E
<input type="checkbox"/>	<input type="checkbox"/>	<input checked="" type="checkbox"/>	<input checked="" type="checkbox"/>	The maximum operating time has been reached (a motor is idle and the stop has not been reached?). Check that the motor is engaged.	E
<input type="checkbox"/>	<input checked="" type="checkbox"/>	<input checked="" type="checkbox"/>	<input type="checkbox"/>	Panel M1 closed before panel M2. Increase the time interval between the movement of both panels.	E
<input type="checkbox"/>	<input checked="" type="checkbox"/>	<input checked="" type="checkbox"/>	<input checked="" type="checkbox"/>	Three obstacles detected in a row during opening. Check the gate movement area.	E
<input checked="" type="checkbox"/>	<input type="checkbox"/>	<input type="checkbox"/>	<input type="checkbox"/>	Three obstacles detected in a row during closing. Check the gate movement area.	E
<input checked="" type="checkbox"/>	<input type="checkbox"/>	<input checked="" type="checkbox"/>	<input type="checkbox"/>	The main power supply has been cut during a movement phase OR the battery is too weak for proper operation.	E
<input checked="" type="checkbox"/>	<input checked="" type="checkbox"/>	<input type="checkbox"/>	<input type="checkbox"/>	Self-learning is not valid (it was never performed or a setting that requires repetition of self-learning has been changed). Start self-learning.	E
<input checked="" type="checkbox"/>	<input checked="" type="checkbox"/>	<input type="checkbox"/>	<input checked="" type="checkbox"/>	Automatic closing has been cancelled. Generated if the gate re-opens 3 times (10 in collective mode) after a photocell has been obstructed during automatic closing OR if the beam was obstructed for more than 3 minutes.	E
<input checked="" type="checkbox"/>	<input checked="" type="checkbox"/>	<input checked="" type="checkbox"/>	<input checked="" type="checkbox"/>	The gate control input (2B) is permanently earthed. Check the connections.	E

2.2 - Manual control

The panels can be manoeuvred without any prior programming, for example during motor installation.

F - MAINTENANCE AND UPKEEP

- To enter manual mode, press **OK** for 3 seconds. LED L4 will flash.
- Press and hold the button for the desired movement.

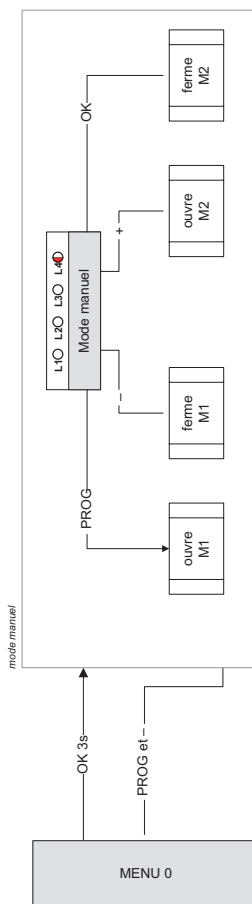

- **PROG** and "+" can be pressed simultaneously, for example, to open both panels at the same time.
- To exit, press **PROG** and "-" simultaneously (press and release).
- Otherwise, after a minute with no action on a button, the system will automatically exit manual control.

In addition, in this mode, LEDs L1 and L2 are used to test the status of the photocell inputs (PHO) and wired control (2B):

If photocells are connected, LED L1 will be on if the infrared beam is unobstructed.

If a wired control device is connected to input 2B, LED L2 turns on when the contactor of the component is activated.

2.3 - Total reset

You can reset to factory settings.

- To do so, press "-" and "+" and **OK** at the same time for 8 seconds until a LED display appears. All the settings now have their default value and you must redo the self-learning.

However, this procedure does not delete the remote controls from the memory.

2.4. Replacing the remote control battery

When the remote control range is very reduced and the red indicator is weak, this means that the remote control battery will soon run out.

The remote control takes CR2032 batteries. Replace the battery with a battery of the same type as originally used.

- With a Philips screwdriver, remove the 3 screws behind the remote control.
- Open the remote control and remove the batteries.
- Insert the new batteries, respecting the polarity.
- Close the remote control and screw in the fastening screws.



2.5. Replacing the power fuse

- Switch the motor drive off.
- Use a 250V 5A time-delay fuse

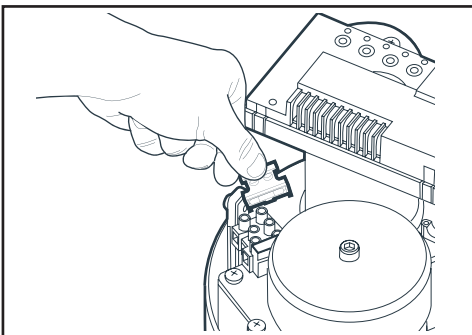

1. COMPATIBLE ACCESSORIES

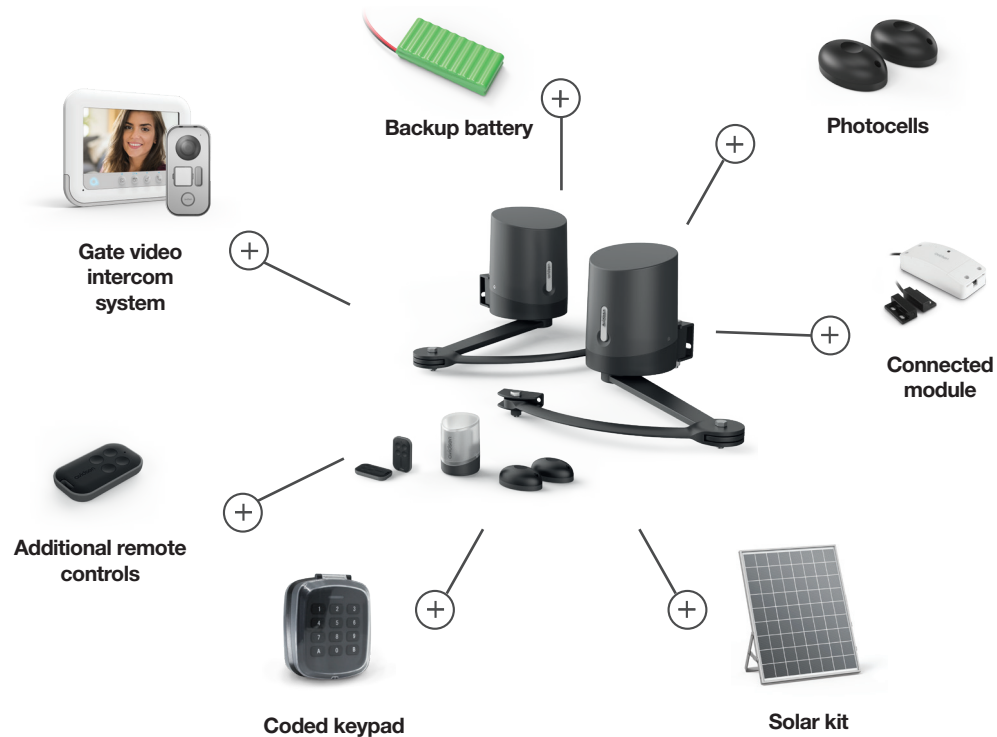

2. TECHNICAL CHARACTERISTICS

The technical characteristics are provided as an indication only and for a temperature of +20°C. Avidsen company reserves the right to modify these characteristics at any time, while under all circumstances guaranteeing these products' smooth operation and the type of use intended, with a view to improving these products.

MOTOR DRIVE	
Type	24 VDC motors, reduction gear, override system
Contents	1 main motor with integrated electronics and 1 secondary motor
Power supply	24 VDC
Rated torque	160 N.m

G - TECHNICAL AND LEGAL INFORMATION

Consumption at rated strength	3 A
Assigned operating duration	10 cycles per hour
Maximum number of cycles	100 cycles per day
Operating temperature	-20°C / +60°C
Protection rating	IP44
Number of remote controls that can be memorised	15

FLASHING LIGHT

Type	LED lighting 8 W max, flashing managed by the electronic card
Power supply	24 V impulse relay
Operating temperature	-20°C / +60°C
Protection rating	IP44

REMOTE CONTROL

Type	AM On/Off Keying (OOK) modulation. 16-bit Rolling code encoder (i.e. 65,536 possible combinations)
Frequency	433.92 MHz
Open air range	80 m
Power supply	CR2032
Buttons	4 buttons
Radiated power	< 10 mW
Battery life	1 year at a rate of 10 x 2 s uses per day
Operating temperature	-20°C / +60°C
Protection rating	IP40 (For indoor use only: home, car or sheltered location)

PHOTOCELLS	
Type	Modular infrared beam presence detector. D type safety system according to EN 12453
Contents	1 TX transmitter and 1 RX receiver
Power supply	12 VDC, 12 VAC, 24 VDC, 24 VAC
Maximum assigned power	0.7 W for the pair
Output	- 1 output with normally closed dry contact (COM/NC) - 1 output with normally open dry contact (COM/NO)
Transmission angle/Reception angle	10° approx. / 10° approx.
Range	15 m maximum (range may be reduced due to weather disruption)
Operating temperature	-20°C / +60°C
Protection rating	IP44

3. WARRANTY

- This product is guaranteed for 3 years, parts and labour for repair.
- Product dismantling and reassembly costs are not covered.
- The warranty does not cover: consumables (batteries, etc.) and damage caused by misuse, improper use, improper installation, external intervention, damage due to physical or electrical shocks, dropping or atmospheric phenomena.
- Do not open the mechanical parts of the motor unit as doing so will void the warranty.
- When returning the product for after-sales service, protect the device to prevent scratches and impacts.
- Clean with a soft cloth only, no solvents. Before cleaning, disconnect the equipment or switch it off at the mains.

Please note: Do not use any carboxylic acid, alcohol, or similar chemicals on the product. In addition to damaging your device, the fumes are also hazardous to your health and are explosive. Do not use any tool that can conduct voltage (wire brush, sharp tool, etc.) for cleaning.

The receipt or invoice is proof of purchase date.

4. HELP AND ADVICE

- If, despite the care we have taken in designing our products and drafting these instructions, you do encounter difficulties when installing your product or you have any questions, we strongly recommend that you contact one of our specialists who will be glad to help.
- If you encounter operating problems during installation or after a few days of use, it is essential for you to be near

your system when contacting us. This will make it possible for one of our technicians to diagnose the source of the problem, as it will probably be the result of a setting that is incorrect or an installation that is not to specification.

Contact our after sales service team technicians:

0 892 701 369

Monday to Friday, 9pm to 12pm, and 2pm to 6pm.

5. PRODUCT RETURNS - AFTER SALES SERVICE

If, despite the care we have taken in designing and manufacturing your product, it needs to be returned to our customer service centre.

Avidsen undertakes to keep a stock of spare parts for this product throughout the contractual warranty period.

6. EU DECLARATION OF CONFORMITY

With the RED directive, Avidsen declares that the following equipment: ORANE 510 pivoting arm motor drive reference 114201 complies with the RED 2014/53/EU directive and its conformity has been assessed pursuant to the applicable standards in force:

- RED EN 300 220-1 V3.1.1
- RED EN 300 220-2 V3.1.1
- LVD EN 62479:2010
- LVD EN 60335-1:2012 + A11:2014
- LVD EN 60335-2-103:2015
- EMC EN 301 489-1 V2.2.0
- EMC EN 301 489-3 V2.1.1
- EMC EN 55014-1:2017
- EMC EN 55014-2:2015
- EMC EN 61000-3-2:2014
- EMC EN 61000-3-3:2013

The remote control included with the abovementioned product complies with the RED 2014/53/EU directive. Its conformity has been assessed pursuant to the applicable standards in force:

- EN 62368-1:2014 + A11:2017
- ETSI EN 301 489-1 V2.2.3:2019
- ETSI EN 301 489-3 V2.1.1:2019
- ETSI EN 300 220-1 V3.1.1:2017
- ETSI EN 300 220-2 V3.2.1:2018
- EN 62479:2010

Tours, 17/09/2025

Alexandre Chaverot, CEO





avidsen

Avidsen
19 avenue Marcel Dassault - ZAC des Deux Lions
37200 Tours - France